

Pratt & Whitney's R-4360

Graham White

Pratt & Whitney's 28-cylinder, four-row radial, the R-4360, was the largest and most complex aircraft piston engine to enter production in the West. After cancellation of P & W's liquid cooled sleeve valve efforts, the R-4360 was rushed into development with an initial rating of over 3000 hp. Although too late for WWII, it played a significant part in postwar military aviation and to a lesser degree, in commercial aviation. Topics covered are: cooling, vibration, bearings, superchargers (including turbocharging and variable discharge turbines), etc. Questions such as how to mount such a behemoth, cowl designs, nacelle design, cooling flow, oil cooling, propellers (including dual rotation) etc., will be addressed. Finally, how many R-4360s are still in service?

KEYWORDS: Large aero-engines.

Introduction

If big is good, then bigger is better, right? Wrong!! The Pratt & Whitney R-4360 was the only aircraft piston engine displacing over 4,000 cubic inches that entered into series production. However, the landscape is littered with attempts at producing a large displacement, high horsepower aircraft engine. This includes air-cooled radials, liquid-cooled in-lines and even liquid-cooled radials. History has indicated that doubling the displacement of an engine causes the development problems to go up exponentially. These problems are associated with cooling, mechanical design, lubrication and weight control.

Of course, engines were developed that could produce in excess of 4,000 horsepower, but for how long would they stay together? There is little point in developing a hot-rod that lasts 200 hours between overhauls. Commercial aviation, in particular, demands reliability with reasonable time between overhauls. Bottom-line economics reign supreme in the unforgiving world of commercial aviation - then and now. Even Pratt & Whitney experienced difficulty meeting these demands with the R-4360. After overcoming innumerable obstacles they managed to meet these demands and were the only manufacturer to achieve this lofty and admirable goal. As a transition to gas turbine power, the R-4360 excelled, although its development was never smooth sailing. It took the efforts of Pratt & Whitney's best engineers to arrive at concepts that would work. And as the gas turbine became prominent, more engineering talent was siphoned off for this new form of motive power, leaving the R-4360 program short of engineering talent at critical

The Piston Engine Revolution

times during its development. What follows is a history of what it took to develop Pratt and Whitney's four-row, twenty-eight cylinder, air-cooled radial.

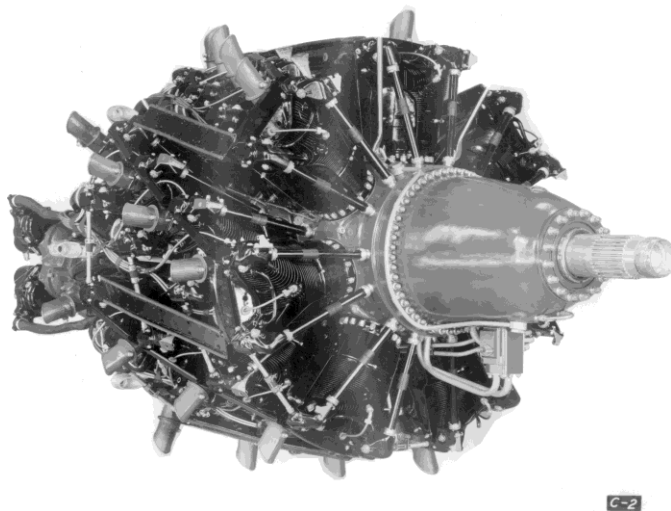

Figure 1. The first of many. Made up from available off-the-shelf components this proof-of-concept engine paved the way to further R-4360 development. This three-quarter right front view shows the B series R-2800 front cylinders and the H-3130 nose case.

(Pratt & Whitney Archives)

The basic question was; how to achieve 4,360 cubic inches and 3000 hp plus - or thereabouts? This was the first of many challenges facing Pratt & Whitney engineers. After their disastrous foray into liquid-cooled sleeve valve engines, led by George Mead, Pratt & Whitney's brilliant engine designer, Luke Hobbs, chose to follow the path they were familiar with; an air-cooled radial. After various variations and permutations, the one combination that appeared possible and offered the most promise was four rows of seven cylinders. Wisely, Pratt & Whitney chose to use the same cylinder dimensions used on the successful R-2800; five and three-quarter inch bore and six inch stroke. Twenty-eight R-2800 sized cylinders resulted, in a displacement of 4,363 cubic inches.

A number of considerations dictated which combination would prevail; firing order and cooling being the primary ones. Intensive studies were carried out, initially using existing R-2800 cylinders. The first proof-of-concept engine featured twenty-eight R-2800 "B" series front cylinders arranged in a right hand spiral. Apart from the cylinders, other off-the-shelf components were used for the initial proof-of-concept engine, including a modified H-3130 nose case and reduction gear, a supercharger, a Bendix PT-13 carburettor from a "B" series R-2800 and R-

The Piston Engine Revolution

2180 connecting rods (Figure 1).¹ Serious design efforts were initiated on 11 November 1940 with the first proof of concept engine running on 28 April 1941. The unusual fore-and-aft valve positions had evolved, though the first attempts placed the exhaust port on top of the cylinder and the intake off to the side. In retrospect, this may have been the better arrangement than the one finally chosen.²

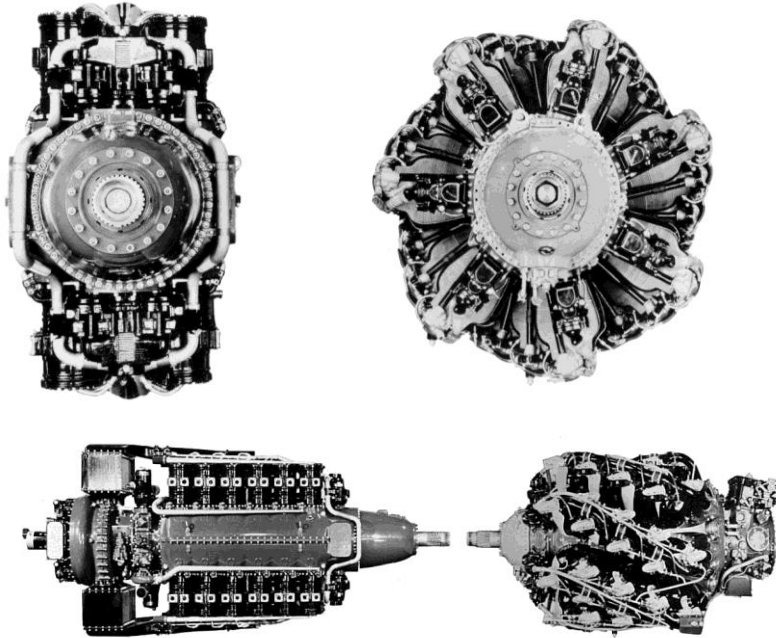

Figure 2. Comparison of the R-4360 and H-3130. Despite having over 1,000 more cubic inches and capable of developing considerably more power than the liquid cooled H-3130, the R-4360 looks quite svelte next to its porkier sibling. Little wonder that Pratt & Whitney threw in the towel with this ill-conceived liquid-cooled sleeve-valve effort.

(Pratt & Whitney Archives)

Even though the United States was not yet enmeshed in World War II, the writing was on the wall; it was only a matter of time, and Luke Hobbs was committed to having the R-4360 ready for combat. As events unravelled, this did not occur but Hobbs only just missed this ambitious goal. As if further proof was necessary to reinforce the decision to put the liquid-cooled projects on the back burner, and stick to a known concept, Pratt & Whitney took a series of photographs to illustrate the difference in frontal area. At that time the prevailing view, especially among European fighter plane designers, was that aircooled radials were much harder to streamline than liquid cooled in line engines. There is some truth in this, but the apparent advantage disappears as engine capacity increases. Pratt &

The Piston Engine Revolution

Whitney took a series of photographs to illustrate the difference in frontal area. The R-4360 was clearly superior in every aspect: reduced frontal area for a significantly greater displacement (Figure 2).

The first flight of a new engine is always fraught with apprehension; however, all was well with the R-4360's maiden flight on 25 April 1942. Powering a modified Vultee Vengeance dive-bomber and designated V-85 (Figure 3), the first flight went smoothly. It was not long, however, before problems bubbled to the surface. One of these problems resulted in the write-off of the V-85 due to a ruptured fuel-feed-nozzle diaphragm. This aircraft met its ignominious end in a tobacco field north of Hartford, Connecticut, fortunately with no injury to the pilot. Pratt & Whitney test pilot Howard H. Sargent Jr performed all initial flights.³



Figure 3. The ram air induction scoop above the cowl, fitted to the V-85, is shown to good advantage in this shot. The metallized rudder (as opposed to the standard fabric covered version) helped the aircraft to handle 3,000 plus horsepower. (Pratt & Whitney Archives)



Figure 4. The R-4360-25 was the production version of the R-4360-5. This typifies a mid-production R-4360. Note the six-inch extension incorporated into the nose case – a feature of all B-36 engines. This extension accommodated the propeller spinner afterbody.

(Pratt & Whitney Archives)

Cylinder Naming and Location

Although prior radial engine practice had been to simply number the cylinders, with the R-4360's 28 cylinders this would not have been the most practical naming convention. Hence each row was given a letter designation, starting at the rear with row "A" and moving forward to the front with row "D". Each cylinder within a row was given a numeric designation. Looking from the rear of the engine, the uppermost cylinder is number one and going clockwise they are numbered up to seven.⁴

R-4360 Main Production Design Features

Unlike the R-2800, for instance, which went through major redesigns, the R-4360 only went through incremental improvements during its production life span.⁵ Figure 4 shows a typical mid-production R-4360.

Now that the basic concept of twenty eight cylinders in four rows had been established, Pratt & Whitney's next goal was how put all the parts together, make it work, put out decent horsepower and cool effectively. With twenty-eight cylinders, even firing dictates that a cylinder fires every 25.714 degrees (720 divided by 28). Spacing between seven cylinders per row is 51.428 degrees (360 divided by 7). Now the question arises; what offset angle to give between cylinder rows. This is arrived at by dividing 25.714 degrees (half of 51.428 degrees) by two, which gives 12.857 degrees. This 12.857-degree offset is what gives the R-4360 its characteristic spiral shape. 12.857 is also $1/28^{\text{th}}$ of 360. The four-throw crankshaft has a similar offset as the cylinders plus 180 degrees or 192.857 degrees. In other words, starting with row "A" with the master rod journal at zero degrees, the next master rod journal for "B" row is displaced at 192.857 degrees, "twisting" in the same direction as the cylinder arrangement and so on.

This arrangement gave a number of advantages; the requisite even firing, and cylinders fired in order for each cylinder bank. In other words, when cylinder A1 (for instance) fires on "A" row, the next cylinder to fire in that cylinder bank is B1, then C1 and finally D1. Furthermore, each bank of cylinders was essentially a four-cylinder inline engine. Typical four-cylinder inline engines have the pistons running in pairs, i.e., when the two end cylinders are at bottom dead centre, the two middle cylinders are at top dead centre. The R-4360 was similar in this regard but instead of the two end cylinders and two middle cylinders running in pairs, the R-4360 ran A1 with C1 and B1 with D1. Therefore when cylinders A1 and C1 are at top dead centre, cylinders B1 and D1 are at bottom dead centre. In this way, the R-4360 can be considered as seven, four-cylinder engines.⁶ Not only did this concept give perfectly even firing but it also had the additional advantage that in the event of a magneto failure, only one bank, i.e., four cylinders, would be lost, which reduces vibration due to uneven firing. For smoothness and reduced engine stress

even firing is always advantageous. See Figure 5 for the naming convention of the major sub-assemblies.

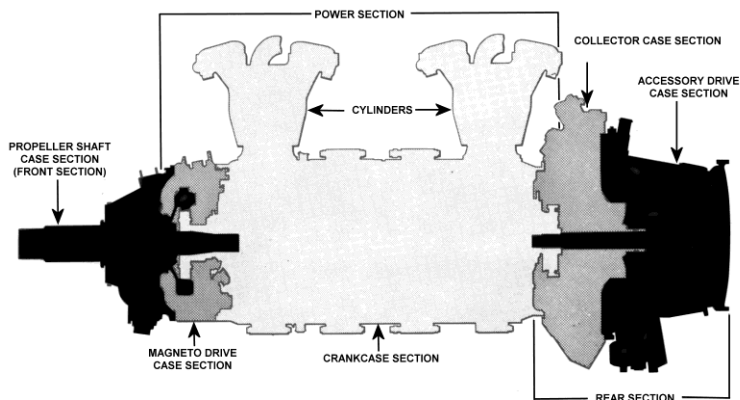

Figure 5. This illustration shows the major sub-assemblies that make up the R-4360.

Firing order is as follows reading across:

| | | | |
|----|----|----|----|
| A1 | B5 | C2 | D6 |
| A3 | B7 | C4 | D1 |
| A5 | B2 | C6 | D3 |
| A7 | B4 | C1 | D5 |
| A2 | B6 | C3 | D7 |
| A4 | B1 | C5 | D2 |
| A6 | B3 | C7 | D4 |

Crankshaft Design

Crankshafts tend to be one of the heavier components of internal combustion engines; they are also one of the more difficult components of which to get right balance and vibration.

A key challenge to the designer is how to lay out the crankshaft and master connecting rods, i.e., one-piece vs. two-piece vs. built-up. For radials two basic schools of thought existed for multi-row radials; one-piece master rod with built up crankshaft, or a two-piece master rod and one-piece crankshaft. Pratt & Whitney had experience with both methods prior to the R-4360. One-piece master rods are preferable, but are fraught with major design and manufacturing challenges. For the R-4360, Pratt & Whitney chose to take the more prudent route of a one-piece crankshaft with split master rods.

The crankshaft used five main bearings and, of course, four master rod journals. The question was how to make the crankshaft light, resist torsional and dynamic vibration, and at the same time hold up to the power and abuse it would suffer during its working life? As previously mentioned, the four throw crankshaft

The Piston Engine Revolution

had the master rod journals spaced at 192.857 degrees between throws. During its early development, the R-4360 was top secret and to make sure it stayed this way some innovative red herrings were implemented. One of these red herrings was to call out five throws on the crankshaft drawings and this is how the first few crankshaft forgings were manufactured by one of Pratt & Whitney's vendors. Of course, as soon as the crank was received at Pratt & Whitney, the extra master rod and main bearing journals were machined off!

Vibration

Because of the complex dynamics of a multi-row radial engine, attenuating torsional and dynamic vibration is a tough assignment. Fortunately, by the time the R-4360 was developed, experience had been gained from previous engine developments. As usual with aircraft engines, conflicting requirements have to be met; those of counterweighting the crankshaft in order to achieve smooth running commensurate with attenuation of torsional and dynamic vibration. Weight had to be kept to a minimum.

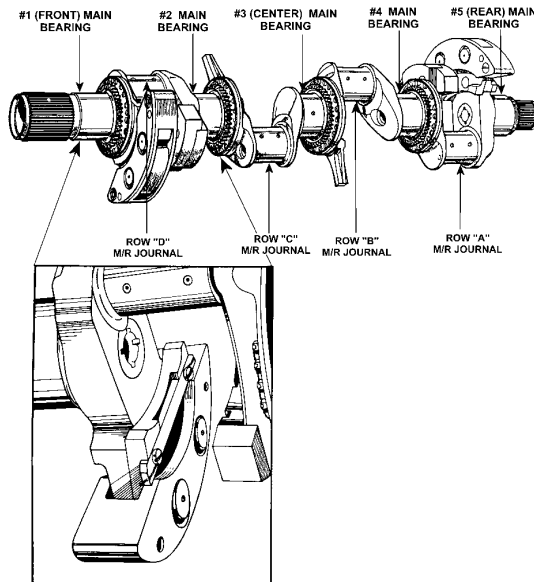

Figure 6. Engineering elegance at its finest – the R-4360 crankshaft. This view also shows to advantage the bifilar dynamic counterweight, the master rod journals and main bearing journals. (Drawn by author based on parts manual illustration)

The pairs of crank throws A, B and C, D each produce additive rocking couples which tend to rotate the crankshaft in a counter clockwise direction. However, these couples and any other unbalanced primary force of significance

The Piston Engine Revolution

may be balanced simply by a pair of dynamic counterweights located at extreme ends of the crank at the number one and number five main bearing crank webs. They are of the “bifilar” type, in other words, a floating dynamic counter weight is supported on two floating bushings and rollers. They are tuned to attenuate the firing frequency of a row or 3-1/2 order (Figure 6).

Crank throws A, B, C and D do not lie in the same plane but are angularly displaced to the same degree as the cylinder offset, in other words, 12.857 degrees plus 180 degrees, or 192.857 degrees. This angular displacement or twist of throws is compensated with regards to balancing by displacing the end (dynamic) counterweights angularity with respect to the crank throws. This removes the need for intermediate or additional counterweights. The front dynamic counterweight is displaced by two degrees, forty two minutes (2.700 deg) in a clockwise direction from the front crankpin (D). In a similar fashion, the rear dynamic counterweight is displaced a similar amount but counter clockwise from the plane of the rear (A) crank throw. To further assist in attenuating vibration, fixed, bolt-on counterweights are attached at the ends of the crank, inboard of the D and A crank throws. Again, these counter weights are displaced from the place of the crank throw in the same direction as their dynamic counterparts. However, this time the displacement is two degrees, forty-two minutes.⁷ Pratt & Whitney called in the cavalry in the form of J.P. Den Hartog, the world’s most respected vibration expert. Early crankshafts were breaking at the crank cheek. In a counterintuitive move, Den Hartog recommended removing material in order to make the crankshaft less rigid. Once again, Den Hartog worked his magic.

Master and Link Rods

Pratt & Whitney had extensive experience in the design of two-piece master rods. Split along the centreline of the master rod bearing, the upper half contained the master rod and a link rod on both sides (Figure 7). The bearing cap contained the four remaining link rods. Bronze bearings are pressed into both ends of each link rod, which ride on hardened steel pins. Four precision bolts attach the cap to its master rod. Each pair of bolts straddles the link rods. Holes drilled through the link-rod pins closest to the bearing parting line allow the bolts to pass through.

Having to contain the immense loading of the master rod, its bearing requires careful design consideration. On later models of R-4360, well over 1,000 horsepower is transmitted through this critical bearing. Of course, not all that 1,000 plus horsepower ends up at the propeller, several hundred horsepower is required to drive the supercharger and accessories, plus a significant amount of power is absorbed through frictional losses. Nevertheless, the R-4360’s master rod bearing does not know this.

As far as this bearing is concerned, upwards of 1,100 horsepower is going through it. Numerous operating requirements including corrosion resistance,

The Piston Engine Revolution

erosion resistance and compatibility with the hardened steel bearing journal need to be accommodated. In addition, a good plain bearing should be sufficiently hard and strong with the requisite fatigue strength to withstand the heavy pressures and hammering, without significant distortion, which are some of the occupational hazards of a master rod bearing.

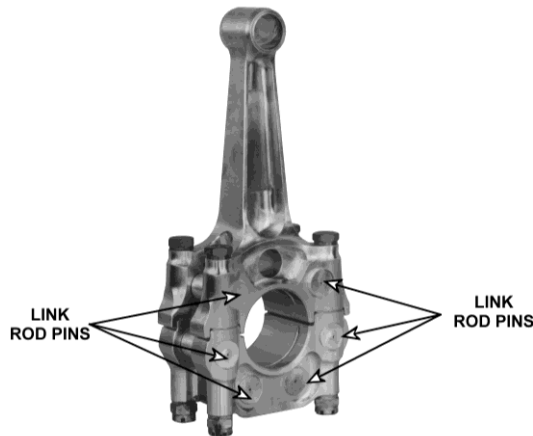

Figure 7. Pratt & Whitney chose to use a conventional design for this highly stressed component. R-1535, R-1830 and R-2000 influence is apparent. These engines also used two piece master rods. (Illustration by author generated from P&W archival material)

One inevitable by-product of running a high performance engine is debris entering the oil system. This debris can take the form of carbon from combustion or wear particles from other engine components. Bearings need to have “embeddibility”, in other words, the capability to absorb small particles of debris within the bearing material, without compromising bearing performance.

Based on Pratt & Whitney’s pioneering work in the 1930s a lead/indium silver bearing is employed, not only for the master rod, but other key load bearing components such as the crankshaft main bearings and reduction gear pinion bearings.

Crankcase Design

Pratt & Whitney found out from its very first engine, the R-1340 Wasp, an aluminium forging offered the best material and mechanical properties for radial engine crankcase construction. Forging offers considerably higher levels of fatigue resistance and improved material properties over cast aluminium. Unprecedented challenges were presented by the need to tie everything together, so the engine was manufacturable and durable. Pratt & Whitney’s solution was to use a five-piece construction with the five sections stacked in line so as to form the basic crankcase (Figure 8). The centre line through each cylinder row represented the parting line

The Piston Engine Revolution

between sections. In this way, the middle of each crankcase section of the three centre sections supports a crankshaft main bearing.

With a one-piece crankshaft, a hole was required in the three centre sections of the crankcase that would accommodate the main bearing carrier. In this

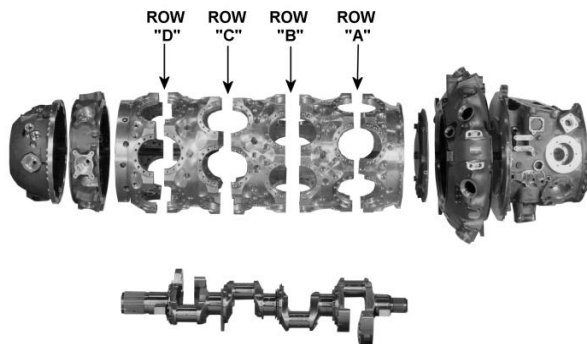

Figure 8. Five piece forged aluminium crankcase. One can only imagine the tolerances required to avoid a huge tolerance stack-up problem when manufacturing this assembly.
(Illustration by author generated from P&W archival material)

way, the crankcase sections could be slipped over the one-piece crankshaft. The three centre main bearing carriers are manufactured from magnesium and are located in a steel ring pressed into the forged aluminium crankcase section. Under operating conditions the magnesium carrier expands more than the steel ring thus ensuring an interference fit and the requisite rigidity.

Valve Mechanism

As long as the intake and exhaust valves open and close at the correct times with the correct acceleration and lift, the engine does not care how these events occur. In the case of the R-4360, it used typical radial engine technology, i.e., cam rings. Each cam ring has an intake and exhaust cam track machined into it. Three lobes per cam track are used which dictates 6:1 reduction gearing between the crank and the cam ring which rotates in the opposite direction to the crank. On later “C” series engines this arrangement was redesigned by utilizing four cam lobes per cam track, rotating in the same direction as the crank with the requisite 8:1 reduction gearing.

The unique configuration of the R-4360’s intake valve at the front, and exhaust valve at the rear of the cylinder, introduces a new set of problems. With conventional radials, a pair of pushrods resides either at the front or the rear of the cylinder. Therefore, one cam ring can drive an entire row of intake and exhaust valve requirements via two cam tracks and associated push rods. Not so with the R-4360. Pratt & Whitney overcame this problem by using five identical cam rings. The front cam ring only operates the intake valves of the “D” row of cylinders.

The Piston Engine Revolution

This means the exhaust cam track is redundant. The next cam ring, which resides between the “D” row and “C” row operates the exhaust valves of the “D” row and the intake valves of the “C” row. Between rows “C” and “B” another cam ring resides and operates in a similar fashion to the one that resides between rows “D” and “C”. The fifth and last cam ring resides at the rear of the engine. In this case, of course, it only actuates the exhaust push rods.

Now that the cam ring set-up has been established, the question is, how are they driven? With a single or two-row radial, a set of reduction gears, driven off the crankshaft, turns the cam ring. But with the R-4360s’ five cam rings a number of difficulties are introduced. The one-piece crankshaft negates the possibility of using one-piece reduction gears driven off the crankshaft. Pratt & Whitney got around this problem by splitting the primary drive gear along its axis, at least for the three centre ones. The two end cam rings presented no problems as far as drive requirements went, one-piece gears are used. The three centre split gears are mounted and clamped on the crankshaft. Each crankshaft main bearing cap is bored through to support a gear driven off the split gear. A shaft that goes through the bored hole in the main bearing cap has a gear mounted on both ends. The gear on one end is driven off the split gear and the gear on the other end drives an internal gear in the cam ring. The two end cam rings are driven in a similar fashion. The three centre main bearing carriers are the same with the exception of the centre one which is shaped to fit within the crankshaft locating flanges. This also offers longitudinal thrust support for the crank. All five main bearing carriers are offset by 12.857 degrees between rows. This allows commonality of parts and makes for easier valve timing when assembling the engine. Additionally, cam drive gears serve double duty by driving a gerotor-type scavenge pump, five in all.

Engine Cooling

At the time of its early design, 1941, Pratt & Whitney were getting into full stride developing a forged cylinder head for the “C” series R-2800. With the capability of unlimited depth and any number of cooling fins, it became a no-brainer to use forged heads. Commensurate with the requirement to keep head temperatures at something below a value that would not cause undue stress to the engine, i.e., less than 500°F (260°C), cooling drag had to be kept to a minimum.

Contrary to popular belief, the drag of a radial engine is not so much related to frontal area but rather to the pressure drop times the mass flow into the engine cowl. In other words a large pressure drop would indicate a large mass air-flow throughout the cowl, which was not good for low drag. It had been determined, via exhaustive testing, that a pressure drop of approximately 12 inches of water would be required. Although this may not sound like much, after performing the calculations the mass air flow requirements get into gas turbine territory. Testing had indicated that a mass air flow of 6,250 pounds per hour per cylinder was required to cool the R-4360 at take-off power. This amounts to a

staggering rate of 175,000 pounds of air per hour at take-off power for the complete engine, or 48.6 pounds of cooling air per second. To put it in other terms, the heat rejection requirements operating at take-off power is a staggering 16,225 BTUs per minute (260 kW) and this does not include the heat rejection from the oil.⁸

It quickly became apparent that all previous ideas and concepts of radial engine design had to be thrown out the window. Bolting more cylinders onto a crankcase simply was not an option. Herein lays the reason why the R-4360 succeeded where others had failed. Normal radial engine cooling, whether it is for a single row or two-row, requires the cooling air follow a straight-through path. That is, cooling air enters the front of a cylinder and exits through the rear, often times aided by baffles placed between the cylinders to ensure the flow went through the fins. The R-4360 concept was quite different. Instead, seven plenums (extended chambers) are created between rows of cylinders. Air enters the plenum and is forced through the cylinders at angle of approximately 30 degrees, creating a quasi cross-flow cooling path (Figure 9).⁹

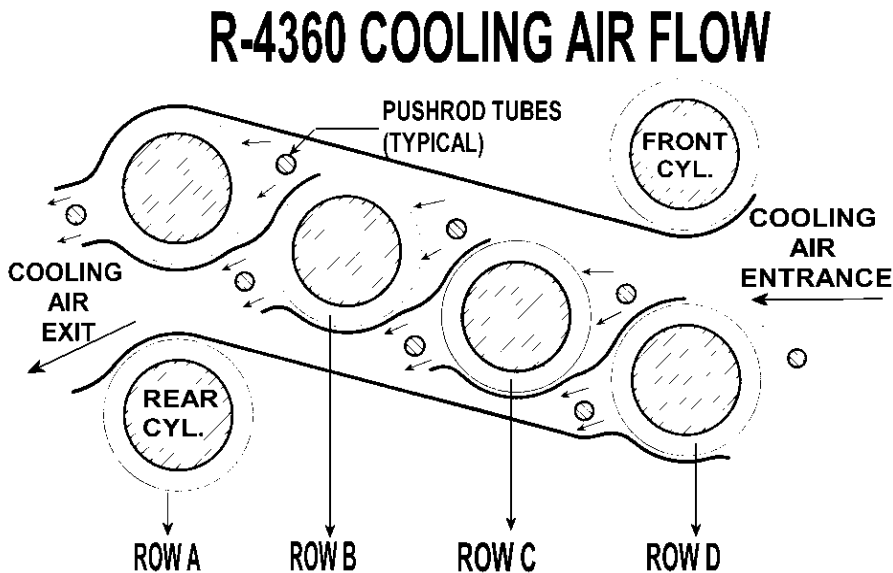

Figure 9. Each bank of four cylinders made up of a plenum system as shown in this line drawing. As can be seen, the cooling flow is quasi cross-flow. (Illustration by author generated from P&W archival material)

Cooling airflow is helped with extensive baffling of the cylinders so every ounce of mass airflow is put to good use. Furthermore, it was imperative that any R-4360 application sealed the cooling air to avoid leakage (Figure 10). Figure 11

shows graphically the required mass airflow for satisfactory cooling. Figure 12 shows an example of reverse flow cooling, as in the B36 bomber, but the basic concept was the same as tractor applications.

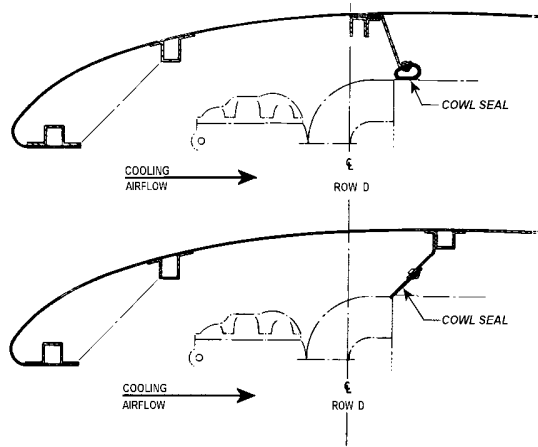

Figure 10. Cooling air that enters the cowl is a precious commodity not to be wasted. It is critical that the outside diameter of the engine is sealed against the inside diameter of the cowl. Any air that leaks past the seals results in wider cowl flap openings to compensate for the leakage. This then leads to a dramatic rise in drag due to parasitic drag of the flaps and more significantly, a greater mass airflow through the cowl.

(Installation Handbook, Section III Supplement F Wasp Major B Series Engines, February 1953. Modified by author)

Figure 11 shows the mass airflow required to keep the temperature of the R-4360 under control. As an example, at take-off power on a 100°F day, over 50 pounds per second is required to keep things cool. Of course, at the start of the take-off roll, this kind of mass air flow is not possible; instead, the engine relies on its 3,500 pounds of mass to absorb heat until sufficient air speed has built up to generate the required air flow through the cooling fins.

Cylinder Design

Following the successful design of the R-2800 combustion chamber, the R-4360 followed suit with a two-valve hemispherical design (Figure 13).¹⁰ Intake and exhaust manifolds would normally take up the volume required for the seven cooling plenums. Now the problem arose of how pack all the manifolds into a very compact space. The solution was to use a “down-draft” intake port. This entailed running the intake manifold over the top of the four cylinder heads that constituted one bank. In this way, the intake manifold was tucked out of the way and offered minimal pressure drop. Interestingly, one of the first prototype engines, the X-109,

The Piston Engine Revolution

reversed the convention described above and used a side intake and top exhaust. This arrangement was not used on any other R-4360. However, when Pratt &

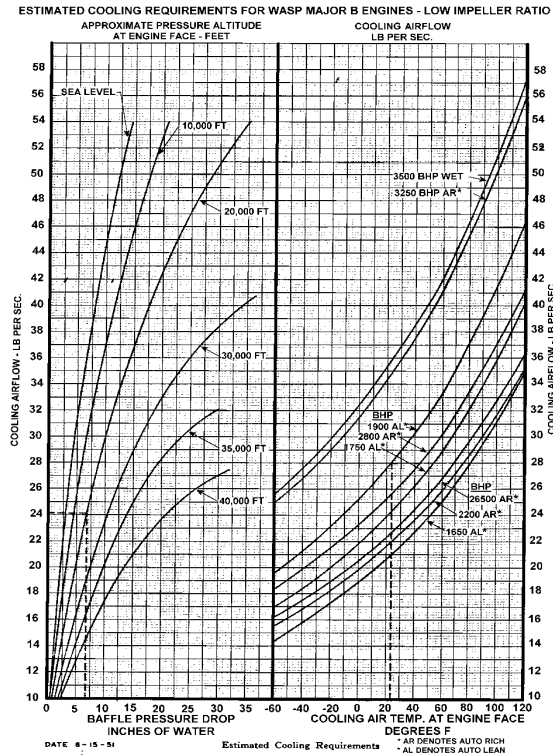

Figure 11. (From Installation Handbook, Section III Supplement F Wasp Major B Series Engines, February 1953. Modified by author)

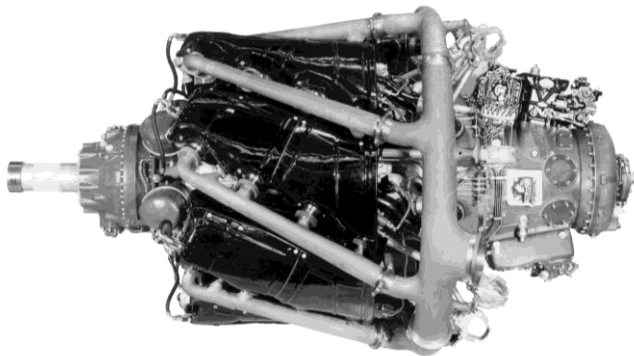

Figure 12. In 1949 the fuel injected R-4360-53 was introduced for the B-36. Each engine developed an additional 300 horsepower, now rated at 3,800. The fact that it was a pusher required reverse flow cooling, fan assisted. (Pratt & Whitney Archives)

The Piston Engine Revolution

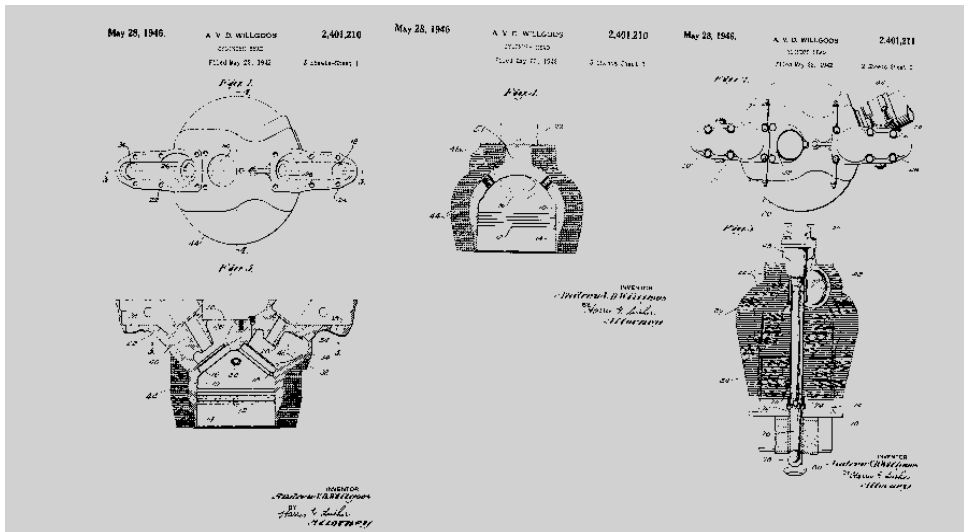

Figure 13. The longitudinal view of the cylinder illustrates the hemispherical combustion chamber and the down draft intake port. The lateral cross section illustrates the position of the dual spark plugs. Also worth mentioning is the depth and number of cooling fins.
(United States Patent 2,401,210)

Whitney developed the R-2180, often described a half R-4360, the top exhaust and side inlet was, once again, employed.

If Pratt & Whitney had simply used the same concept for pushrod location as that used on other radial engines, i.e., intake and exhaust pushrods located at the front or rear of the cylinder, the R-4360 would have experienced problems with its intake and exhaust port design not to mention some awkward cam ring configurations. The inlet, in particular, owing to the right hand spiral, would have required doglegs designed into it. To overcome this, Pratt & Whitney rotated the cylinder about the engine's axis so that the inlet pushrod was at the front and the exhaust pushrod was at the rear of the cylinder.

As mentioned above, R-4360s used forged cylinder heads. But due to the severe cooling requirements of this engine, materials other than aluminium were investigated for the cylinder head. Copper is a well-known conductor of heat, rather better than aluminium, but is accompanied by a significant weight penalty. A Pratt & Whitney Memorandum Report issued in 1941 summarized the pros and cons of aluminium vs. copper:

- For a fixed fin length, irrespective of weight and pumping power limitations, copper fins give the greatest heat transfer.
- For a given fin weight, irrespective of length and pumping power limitations, aluminium fins give greater heat transfer than copper.

The Piston Engine Revolution

- For a specified pumping power irrespective of fin length and weight limitations, copper fins give greater heat transfer than aluminium¹¹

All cylinders were interchangeable, unlike most other multi-row radial which require different cylinders for the front and rear rows. Even more remarkable was the fact cylinders could be rotated 180 degrees to accommodate a pusher or tractor installation. However, a different cam rings would be required depending on whether it was a pusher or tractor. Even so, this clearly helped with spare parts inventories for the military which operated R-4360s in both configurations.

Construction of the R-4360 cylinder followed advanced air-cooled radial practice, i.e., the forged head is screwed and shrunk onto a steel barrel. Prior to this operation, a forged aluminium cooling-muff is shrunk on to the head of the barrel and all cooling fins machined in. The degree of shrink for the head to barrel and cooling muff to barrel dialled-in the requisite cylinder “choke” (Choke in this context means the reduction in diameter of the cylinder because of the shrink fit of the muff). At operating temperature, the choke almost goes away due to thermal expansion. Interestingly, all cooling fins on the barrel as well as the cylinder head are in the horizontal axis. Not only does this improve cooling, it makes for an easier manufacturing job in not having to worry about machining fins in two (horizontal and vertical) axes.

Cylinder Flexing

Another serious problem plaguing R-4360 development was that of cylinders flexing due to valve opening forces.¹² The exhaust valve rocker box was the primary culprit. In order to obtain good volumetric efficiency and exhaust scavenging, it is important to open the exhaust valve well before bottom dead centre of the power stroke. But in so doing, considerable residual pressure is still present inside the cylinder – up to 100 pounds per square inch. The residual exhaust pressure bears against the closed exhaust valve, and with a valve area of about 5.4 square inches this means a force of 540 pounds is required just to overcome exhaust gas pressure. In addition to exhaust gas pressure is the valve spring pressure of 900 pounds (author’s calculations). Additional force is required to accelerate the rocker arm assembly that has a negative mechanical advantage. If weight were not an issue it would simply be a case of making the cylinder out of lots of cast iron or adding considerable amounts of aluminium. But an aircraft engine does not enjoy the luxury of simply adding material to make up for a design shortfall. Under test, the entire valve train was under such stress, the entire system took on the characteristics of a rubber band. As the tappet roller rode up the cam profile, residual exhaust gas pressure resisted opening of the exhaust valve. Something had to give so the exhaust rocker box “ear” would flex until sufficient force had been built up in the system to release the pent-up pressure and force the

valve open. When it did open, it opened with a bang to the extent that the exhaust tappet would bounce off its cam track.

Simply adding stiffer valve springs was not a viable solution; in fact it only exacerbated the situation. Careful beefing up the valve rocker box areas where they overhung the cylinder helped, but it was always marginal. The cam profile was an additional modification. As a starting point, the same profile as that used on the R-2800 was employed. Then a gentle ramp was designed to “ease” the exhaust valve off its seat. To overcome this and other problems, the Air Force undertook numerous tests with various valve clearances ranging from 0.045 inches to 0.060 inches. With the foregoing in mind, it is easy to see why the R-4360 demanded strict adherence to valve clearance checks. If they were not adhered to, serious problems would ensue, such as valve bounce.

Intake Manifold Design

In the case of the R-4360, seven radial outlets from the blower housing connect to tubes which then reached over the top of each bank of four cylinders.¹³ Each cylinder “tees-off” from the intake manifold. Each manifold is made up of four pieces including three “tees”. It terminates at the “D” (front) row of cylinders. In this way, a bank of four cylinders is fed by one of the seven intake manifold assemblies. Early manifolds simply joined the sections with three rubber hoses and hose clamps. This soon proved to be impractical, in part because of the amount of flexing between cylinders. The definitive fix was the use of coupling fitted with rubber chevron seals. This allowed the intake manifold sections to flex and at the same time seal the pressurized fuel/air mixture (Figure 14).



Figure 14. Two styles of intake manifold design. Early, “hose clamp” type at top and later chevron seal type at bottom.

To Scavenge or Not to Scavenge

A dry sump lubrication system was employed. Two main lines connect the tank to the engine: “oil in” and “oil out”. As their names suggest, the oil-in line supplies oil to the suction side of the main engine pressure pump. After performing its lubrication duties, the oil is sucked out of the engine via scavenge pumps through the “oil-out” line. Scavenge oil (oil out) is pumped through a cooler(s) and then back to the oil tank. The preceding is an overly simplified description of oil flow but gives a basic idea of the dry sump concept. Getting lubricating oil to bearings, cylinders and other components that come into intimate contact is, of course essential. But getting the oil out after it has performed its lubricating duties is just as important. Pratt & Whitney learned this valuable lesson when developing the R-2800. Early “A” series R-2800s were rated at 1850 horsepower. Follow-on “B” series R-2800s were rated at 2000 horsepower. The additional 150 horsepower came by simply improving the scavenging efficiency of the oil system. And this improvement was obtained through the ridiculously simple expedient of opening up drain holes in the crankcase sections. As an added bonus, the “B” series engine imparted less heat in the oil so a smaller oil-cooler could be used. When oil is thrashed around inside an engine it not only creates a significant amount of drag, it also causes oil temperatures to go through the roof. Scavenging is essential to maintain good power and keep heat rejection to the oil to a minimum. But it is not always a question of simply bolting on bigger pumps, turning them faster or offering better drainage paths for the oil, although these remedies obviously have their place. As a Pratt & Whitney executive succinctly put it in a 1940s report: “In plain English it can be stated that the initial R-4360 wouldn’t scavenge no-how”¹⁴

It took two and a half years of intensive work to get the scavenging problem under control. This work included the obvious solutions of increasing scavenge pump capacity, installing more scavenge pumps, revising inlet conditions of scavenge pumps, etc. The problem was exacerbated when testing the initial proof-of-concept R-4360 powered F4U WM Corsair. Due to the very high power-to-weight ratio of this aircraft, it was capable of extremely steep climb angles. This capability imposed an additional burden on the scavenge system.

When oil is picked up by the scavenge system, it has been well and truly beaten into a froth, i.e., aerated. And herein lay part of the R-4360’s scavenging woes, oil was hopelessly aerated when picked up by the scavenge pumps. Like many great ideas, the solution was deceptively simple and yet worked like a charm. Just adding sheet metal perforated screens, especially in the rear section, removed a significant portion of the entrapped air before the oil was allowed to enter the suction side of the scavenge pumps. This is a technique used to this day in high performance engines regardless of whether they are dry sump or wet sump. The analogy used by Pratt & Whitney engineers when they arrived at this solution was that of the kitchen sink. If soapy water is beaten into a froth and then the plug is

The Piston Engine Revolution

pulled, the water will not drain. Put a strainer in and the frothy water will drain a lot easier.

In another departure from previous practice, the R-4360 used a geroter type scavenge pump in each crankcase section. These four pumps were driven off the cam drive gears. It is unclear when the geroter type pump was first developed but the R-4360 must have been one of the first applications of this type. Geroter pumps are now used almost universally in automobiles.¹⁵

Ignition

Two basic types of ignition systems were employed by the R-4360: high tension and low tension. The better of the two was demonstrably low tension; however, this superior system was still under development during the R-4360's embryonic years. A significant problem when operating an ignition system at high altitude was that of cross fire (a type of short-circuiting) due to the low dielectric strength of the upper atmosphere. With the reduced insulation value of the upper atmosphere, it was possible for the 20,000 volt high tension intended for the spark plug to take the path of least resistance. This resulted in cross firing inside the magneto. Low-tension ignition solved these and other ignition related woes. Instead of generating 20,000, or greater, voltage, the magneto generates 100 to 150 volts. High tension is generated at the cylinder head via step-up transformer or coil – one for each of the 56 spark plugs. Early B-36s fitted with high-tension ignition suffered greatly with ignition problems because of the high altitude capability of this remarkable aircraft. Over 50,000 ft was attained with the lightly loaded reconnaissance versions of this aircraft.

High-Tension

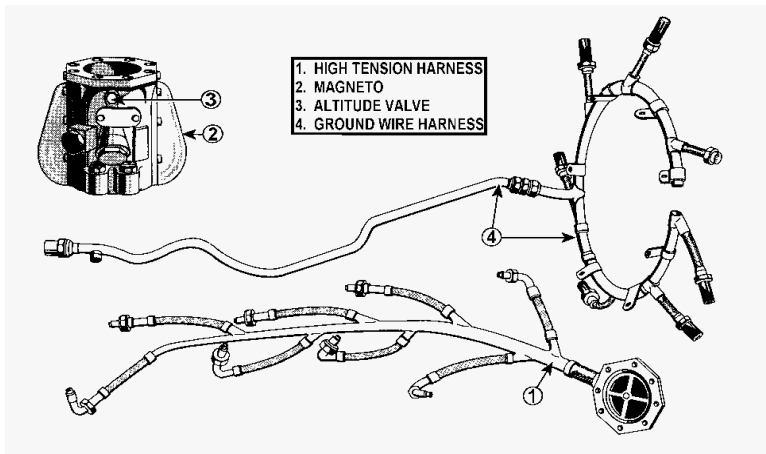

Figure 15. One of the seven harnesses and magnetos that make up a high-tension ignition system. (Service Instructions Bendix-Scintilla Ignition System Used On Pratt & Whitney R-4360 Wasp Major Aircraft Engines. Revised October 1948)

The Piston Engine Revolution

All early R-4360s used high-tension ignition in the form of seven Bendix D-4RN-2 magnetos. Arranged radial fashion around the periphery of the magneto drive case, the magnetos each fired eight spark plugs in the four cylinders making up a bank (Figure 15). Unlike many ignition systems, both magneto and distributor requirements are assembled in one unit. In the event of a magneto failing, four cylinders would drop out leaving the remaining 24 cylinders to pick up the slack.¹⁶ With the high altitude capability of the R-4360, it was inevitable that high altitude flashover would occur. The usual answer to in this scenario is to pressurize the magnetos. A pressurization pump ensured that a sea-level atmosphere was maintained within the magneto regardless of altitude. Even this arrangement had its problems. It was critical that pressurized air was allowed to bleed off, otherwise dangerous amounts of nitric acid would build up in the distributor (the nitric oxide presumably coming from electrical discharges).

Low-Tension

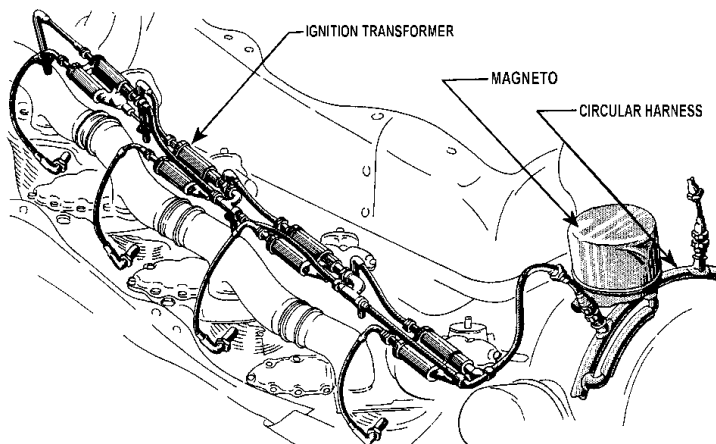

Figure 16. This line drawing shows one of the low-tension magnetos feeding power, via a fully shielded manifold, to the four cylinders that make up a bank. Note the pair of step-up transformers mounted on each cylinder head that boost voltage to the required 20,000 plus volts. Each spark plug had its own high-tension coil, 56 in all. (Handbook Erection and Maintenance Instructions USAF Series B-36F Aircraft. 27 March 1951)

Once the clear advantage of low-tension ignition had been proved with some models of the “C” series R-2800, the R-4360 followed suit. For highflying aircraft such as the B-36 low-tension ignition solved many operating and maintenance woes. Still arranged radial fashion around the front accessory case, the number of magnetos was reduced to four. Each magneto fired the seven cylinders making up a row (Figure 16).¹⁷ Unlike other engines employing low-tension ignition, the R-4360 used a boost coil for each spark plug, 56 in all. Normal practice was to use a

single boost coil per cylinder with two outputs, one for the front plug and one for the rear.

Front Section

Following a similar concept to the “C” series R-2800, the front section was made up of two major assemblies; the “propeller shaft case” and the “magneto drive case”.¹⁸

The propeller shaft section houses a massive rolling element bearing to carry the immense radial and axial loads. This bearing has a split inner race to assist in engine assembly. A large nut retains the inner race and also transmits the engine’s thrust through the engine, engine mount and into the airframe. A plate bolted to the propeller shaft case retains the outer race. This bearing is the only rolling element bearing in the entire engine; all others are plain. Most, but not all, single rotation shafts featured an SAE # 60 spline (Figure 17).

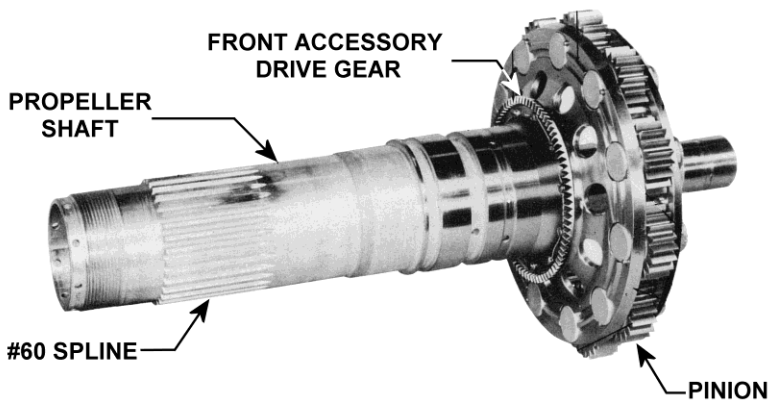

Figure 17. Front nose case assembly.
(Wasp Major Models B6 and CB2 Overhaul Manual Issued June 1953)

There were several exceptions to this convention; in the early “X Wasp” engines and the R-4360-63/A installed in the Douglas Globemaster, both of which employed an SAE #70 splineshaft, the propeller shaft’s rear, or pilot, end is supported by two steel-backed bronze plain bearings. These bearings are inserted in the front of the crankshaft. Although piloting the rear of the propeller shaft in the crankshaft sounds convenient, as with any action consequences result. (“Piloting” can be described as form of support. A classic automobile example is the pilot bearing mounted in the flywheel for the first motion shaft).

The Piston Engine Revolution

These consequences include additional loads placed upon the front main crankshaft bearing. Two compartments, separated by a plug, make up the interior of the propeller shaft; the front accepts oil from the oil transfer bearing and provides oil for hydraulically operated propellers. Lubricating oil for the reduction gearing comes from the rear compartment.

A multi-pinion epicyclic reduction gearing is also housed in the propeller shaft case. The 11 or 16 small pinions, depending on reduction ratio, ride in a pinion shaft support integral with the propeller shaft. A sun gear, driven off the crankshaft, engages the pinions on their inner diameter. Their outer diameter runs in a stationary gear. Following good gear design practice, the pinions were phased to engage sequentially, in other words they do not engage simultaneously. It should be understood that a straight cut involute gear does not transmit power in a smooth, constant velocity manner. But this shortcoming can be mitigated via the aforementioned sequential engagement. In this way, potentially destructive vibration modes are avoided. Even in today's environment, it would require some serious computing power to figure this out; in the days of the R-4360's development, it was all done on a slide rule. A bevel gear, attached to the pinion shaft support, drives the propeller governor and the front section scavenge pump which mounts at the bottom of the propeller shaft case. This scavenge pump is made up of three chambers; the top one scavenges oil from the propeller shaft case and magneto drive housing, the middle chamber scavenges the rocker box front sump and the bottom chamber scavenges the front cam compartment.

The magneto drive housing, sandwiched between the propeller shaft section and the front of the crankcase, is packed full of components. These include the magneto drive requirements, seven magnetos, spark advance mechanism and the torquemeter.

Not all R-4360s were equipped with a torquemeter. The magneto drive housing could accommodate a torquemeter, or simply have a bolted-on fixed gear that would not have the capability of registering a torque reading. Design of the torquemeter followed "C" series R-2800 practices except more pistons are used in order to handle the additional power of the R-4360 (Figure 18). The principle of the torquemeter is quite simple. The fixed gear in the planetary reduction gearing reacts to the power being transmitted. The outer diameter of the fixed gear has a helical spline machined on its periphery. Therefore, as power is transmitted, if the fixed gear were not restrained, it would try to ride forward due to the resultant force generated. Pistons located around the fixed gear's front face offer an equal but opposing reaction. Engine oil, whose pressure is boosted by a torquemeter pump, offers the appropriate restraining force. Boosted oil is fed to all 42 pistons. Reading the pressure generated gives a cockpit reading of torquemeter pressure.

An example of exquisite workmanship and engineering, the automatic spark advance unit consisted of four spark advance cylinders, a compound epicyclic drive, stationary spark advance gear and a compound gear. The spark advance gear

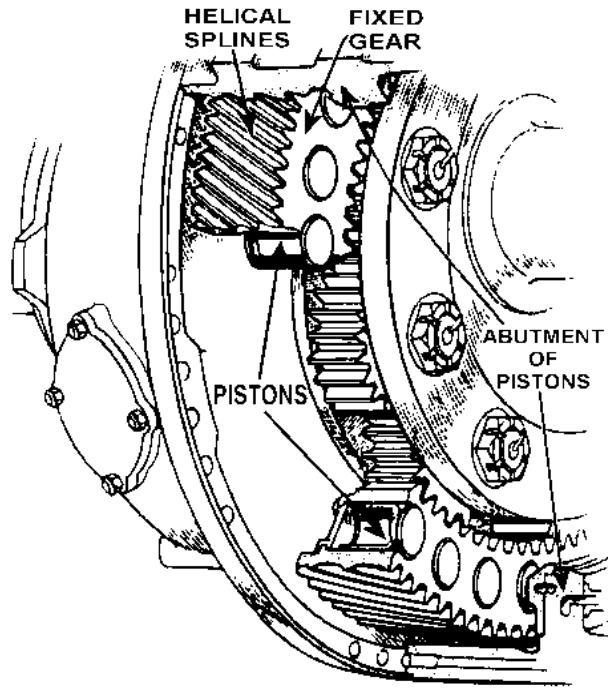

Figure 18. This line drawing of the torque meter shows the key components in a partial cutaway and their relationship to each other. The fixed gear is thrust forward under the influence of power being transmitted through the pinions. Reacting to this force are six hydraulic pistons that give a read-out of torque in pounds/feet, or BMEP. (Wasp Major Models B6 and CB2 Overhaul Manual Issued June 1953)

that performs the function of changing the relationship of the magnetos to the cranks, and consequently the ignition timing, has two arms. Each of these arms is connected to a pair of pistons which are allowed to pivot on both ends. A link made up from a straight beam is pivoted in the middle and attached to the spark advance gear. Each piston is spring loaded with the spring tension forcing the spark advance gear into minimum spark advance. This places the magneto timing in the correct position for starting, i.e., 5 degrees before top dead centre. As oil pressure builds up after engine start, the pistons are allowed travel out and advance the spark timing to 20 degrees before top dead centre. Moving the stationary gear under the influence of the four pistons changes the relationship of the magneto drive to the crankshaft and, in consequence, the ignition timing. The magneto drive pinion cage, splined to the front of the crankshaft, supports seven magneto drive pinions. The front and larger gear of the compound pinion engages with the spark advance gear and the smaller gear of the compound pinion drives the magneto intermediate drive gear. Driven off the crankshaft, the pinion cage rotates within the spark

The Piston Engine Revolution

advance gear, which in turn drives the magneto intermediate drive gear that is supported on a journal formed on the front of the crankshaft. The bevel gear, formed integral with the magneto intermediate drive gear, drives the magneto drive gears, attached to each magneto via a drive shaft.

To summarise: this is a beautifully designed unit, whereby the spark advance “reads” manifold pressure that in turn sends a signal to the four pistons to control the oil pressure in the cylinders, thus changing ignition timing.

Dual/Contra-Rotating Nose Cases

A 3,000 to 4,000 horsepower engine sounds very attractive to the airframe manufacturers, which is why all the major aircraft companies designed at least one aircraft around the R-4360. However, that prodigious power comes with liabilities, mainly in the form of torque reaction. One solution was contra-rotating propellers. The drawback is added weight from the increased gearing and the weight and complexity of an additional propeller. A good example of the propeller issue was the ill-fated Hughes XF-11 which featured a Hamilton Standard “Super” Hydromatic propeller. Failure of one of the propellers almost cost Hughes his life. But apart from the XF-11, a number of aircraft were powered by R-4360s driving contra-rotating propellers. These included the Northrop XB-35, Boeing XF8B-1 and Douglas XTB2D-1 Skypirate. None of these aircraft entered full scale production.

Inner Workings

Looking at photographs of R-4360s with dual rotation propeller shafts it is hard to envisage how it was done, since the nose case hardly looks any larger than a single rotation nose case. The secret was a beautifully designed and compact arrangement that utilized available space to the full (Figure 19). Typically, the two propeller shafts would employ SAE #60 spline (inner) and a larger SAE #80 spline (outer) shafts. The inner (SAE #60 spline) propeller shaft is driven in the normal way, i.e., through planetary reduction gearing. Drive to the outer (SAE #80 spline) shaft is derived from a large diameter “Reverse Drive Gear”. This reverse drive gear is a bevel gear that drives fourteen small fixed bevel pinion gears. This is where the reversing motion takes place. The fourteen small bevel gears drive an outer propeller shaft drive gear.¹⁹ It is somewhat similar to a Farmen planetary gear.

All U.S. built high horsepower engines used SAE propeller splines. The numbering system can be confusing because the SAE spline number does not relate to how many splines are actually incorporated. For instance, an SAE #60 spline shaft does not have 60 splines. Table 2-1 shows how shaft size relates to the horsepower being transmitted. There are exceptions, however. For instance, some “B” series R-2800s were capable of producing far more than 2,000 horsepower and yet used a 50-spline shaft. When the “C” series R-2800 was introduced, a 60-spline shaft was employed.

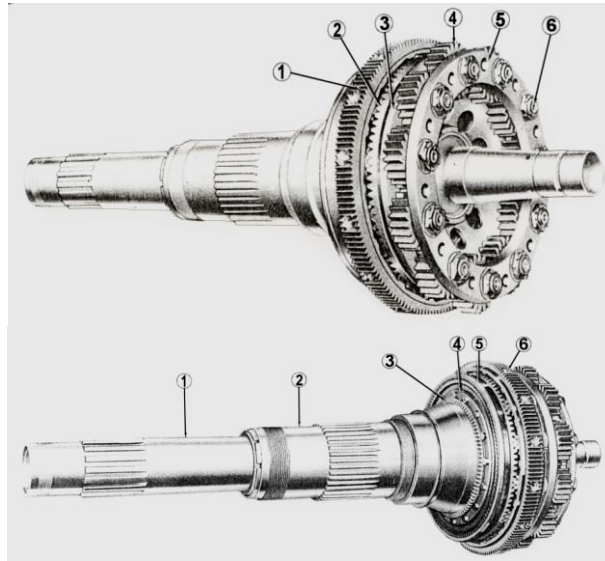

Figure 19. A number of prototype aircraft were fitted with dual rotation propellers. Pratt & Whitney arrived at an innovative solution for the drive requirements.

1. Reverser pinion cage, 2. Reverse drive gear, 3. Reduction drive pinion shaft front support, 4. Reduction drive pinion, 5. Reduction drive pinion shaft rear support, 6. Reduction drive pinion shaft. (Handbook Service Instructions Models R-4360-17, -21, -45 and -47 Aircraft Engines 1 August 1948)

Table 1 Relationship of Propeller Spline Size vs. Power Capability

| SPLINE | HORSEPOWER CAPABILITY |
|--------|-----------------------|
| #50 | 2,000 HORESPOWER |
| #60 | 3,500 |
| #70 | 4,500 |
| #80 | OVER 5,000* |

*Although R-4360s were not capable of producing 5,000 horsepower, the #80 spline configuration was a necessity for the outer propeller shaft on dual rotation applications.

Rear Section

The rear section can be considered everything behind the crankcase. This means the supercharger, accessory drive housing, intake ducting from the carburettor and auxiliary drive housing.

Supercharger

With the exception of the VDT engines, all R-4360s used some form of gear driven supercharger. Right from the initial design studies, flexibility was designed into the

The Piston Engine Revolution

R-4360. Depending on mission profile, R-4360s could have the following supercharger configurations; (i) relatively simple and basic single stage, single speed supercharger, (ii) single stage, two speed, (iii) single stage - variable speed, (iv) single stage with an auxiliary intercooled gear driven supercharger and (v) single stage augmented by turbosupercharging. The foregoing does not include the VDT which utilized turbosupercharging for all its boost requirements.

The supercharger casing (Figure 20) is made from a complex and intricate magnesium casting bolted to the crankcase via a ring of studs of the “wasted” type (for fatigue resistance). Residing inside the supercharger casing are the step-up gears for the supercharger. As stated above, this drive train could have a number of configurations. With the simple single stage, single speed blower, a two-stage step-up gear is used to obtain the appropriate ratio. All the engines augmented with turbo-supercharging used this set-up. Drive for all blower variations emanates from the rear of the crankshaft through a device called a “spring” drive made up from two assemblies.

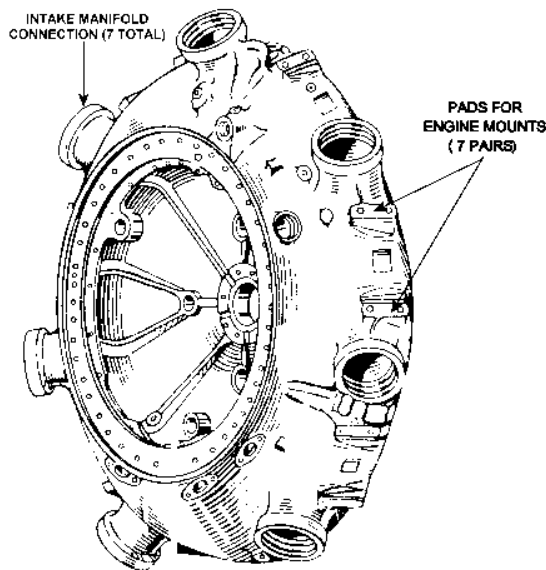

Figure 20. Supercharger casing.

Mounted on the rear of the crankshaft, the drive features six coil springs, mounted inside the assembly, which are in compression. A spider, driven off the crank makes up the central portion of this assembly. Power is transmitted to the gear via the six compression springs and spider to the gear that makes up the outer part of the assembly. The entire assembly is sealed on both sides via plates bolted to the gear. High-pressure oil introduced into the spring drive offers additional hydraulic

The Piston Engine Revolution

damping. As can be gathered from this brief description, driving high-speed superchargers is a major design challenge, one of them being protecting gears from torsional vibration, originating from the crank.

The single-stage, two-speed engines used a similar design except cone clutches were incorporated (Figure 21). One clutch would be used for low blower and, due to the increased power requirements to drive it, two clutches are used for high blower. Single-stage variable-speed blowers incorporated some quite innovative engineering. A pair of hydraulic couplings offers a low ratio and another pair of hydraulic couplings offers a high ratio. Although fluid couplings offer tremendous flexibility with respect to input speed compared to output speed, there is a penalty to pay. When the input speed varies by more than ten percent of the output speed, efficiency goes down because of the slip in the system. This inefficiency is transferred into heat, which places a greater burden on the entire lubrication system, particularly with regards cooling.

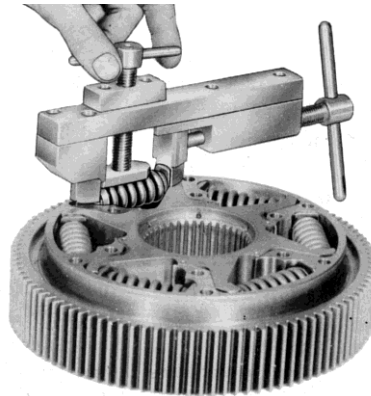

Figure 21. Cushioned spring drive for supercharger.

With the use of two fluid couplings there is a seamless transition between the slowest speed in low ratio and the highest speed in the high ratio due to the operating characteristics of this type of drive. The couplings used for the R-4360 blower drive were typical of their genre; divided into two basic halves, one being the driver, or impeller, and the other being the driven or runner. Drive for the impeller comes from the spring drive.

A sleeve type valve with a leaded-silver bearing surface on its outer diameter and front face is installed on the shaft of each low-ratio coupling pinion between the coupling impeller and runner. A spacer, instead of a valve occupies a similar position in each high ratio coupling. Bronze friction ring segments that contact the bore of the runner are installed in the ring groove located in the outer diameter of each valve. Pins in the bottom of the groove prevent the bronze ring segments from turning with respect to the valve. Pins in the hub of the coupling

impeller engage slots in the rear face of the valve, thereby limiting movement of the valve with respect to the coupling impeller.

While the speed of the coupling impeller is greater than the speed of the runner, the valve turns with the coupling impeller and the valve's oil holes are aligned with the oil holes in the pinion's shaft. Under the conditions just described, oil flows from the shafts (two per ratio) into the pair of couplings and the low ratio coupling impellers, hydraulically engaged by the low ratio coupling impellers, drive the supercharger impeller drive gear at a fixed ratio in a similar fashion to the low ratio of a two speed engine.

When high pressure oil is directed to the high ratio couplings, the high ratio runners, hydraulically engaged by the high ratio coupling impellers, drive the supercharger impeller drive gear at variable ratios, i.e., variable speed, up to a fixed maximum ratio. Oil metered into the high ratio coupling determines the drive ratio. Under these conditions and when the low ratio runner, which is meshing with the supercharger impeller drive gear, rotates faster than the low coupling impellers, the friction between each low ratio coupling valve and the runner causes the valve to turn on the shaft of the pinion in the direction of coupling rotation. When the valve turns, its oil holes move out of alignment with the oil holes in the pinion shaft, thereby cutting off the flow of high pressure oil into the low ratio coupling and thus preventing low ratio coupling operation from interfering with high ratio coupling operation. In other words, it ensures two blower speeds are not engaged at the same time.

When high pressure oil is cut off from the high ratio couplings, to such an extent that the speed of the low ratio coupling runners becomes less than the speed of the low ratio coupling impellers, the friction between each low ratio coupling valve and coupling runner will then cause the valve to turn on the shaft of the pinion in a direction opposite to that of coupling rotation. When the valves turn, their oil holes will line up with the oil holes in the shafts of the pinions and oil will, once again, fill the low ratio coupling and thus provide drive to the supercharger drive gear.

Supercharger Impeller Assembly

Although typical of its type, the centrifugal supercharger employed by the R-4360 benefited from years of prior experience using this method of boosting manifold pressure. Although ostensibly a centrifugal supercharger, the impeller employed a significant axial flow component. A significant change from other Pratt & Whitney impellers was the use of a shroud for the inducer.²⁰ Although early impellers were cast in one piece, Pratt & Whitney designed an impeller with a pressed-on shroud. This introduces a number of difficulties. Due to the high rotational speed of the impeller, up to 27,000rpm for later engines, hoop stresses expanded the shroud and thus lost its interference fit. An intensive development program followed where a number of alternatives were tried including various plastics, fibreglass, steel and

The Piston Engine Revolution

combinations of these and other materials. A shroud made from 4340 chrome molybdenum steel shrunk onto the impeller was finally determined to be the best combination. At an overload speed of 30,000rpm an interference fit still existed - but barely.

The impeller assembly is made up of a shaft assembly, impeller and drive gear. As described above, all four hydraulic coupling gears are in constant mesh with the supercharger impeller gear. Of course, drive to the supercharger impeller is only provided by one pair of hydraulic coupling gears at any one time. Support for the supercharger impeller shaft comes from steel backed bronze bearings.

In 1942 Pratt & Whitney patented their “slinger ring” concept of fuel distribution.²¹ Wright Aeronautical copied this unique method of getting fuel accurately distributed for its radials such as the later R-1820s and R-3350s (Figure 22). Fuel enters the supercharger via the fuel feed valve, essentially a low-pressure pintle-type valve. Fuel is injected into an annular groove machined into the impeller shaft. To avoid fuel leaking into the blower section, sealing rings are employed. Therefore, fuel injected into the annular groove can only go to one place; into the impeller throat. A ring, the so-called slinger ring, picks up fuel from the annular groove. With multiple small hole drilled into its periphery, fuel is centrifuged into the eye of the impeller where it gets slung out under the powerful influence of centrifugal force. Further assisting fuel distribution are galleries drilled between each vane of the supercharger impeller, thus some fuel enters these galleries to be slung out through exit holes positioned at about half the diameter of the impeller.

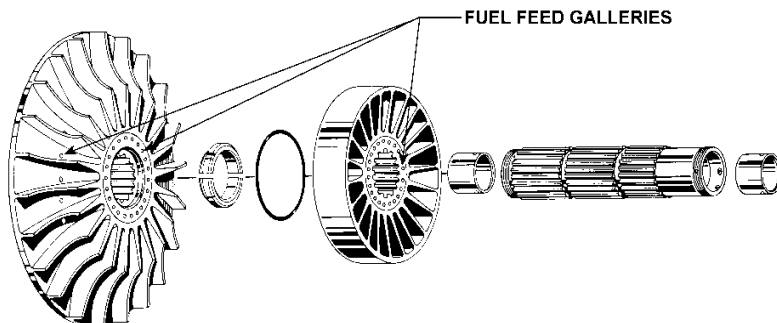

Figure 22. Supercharger shaft and impeller assembly showing unique fuel feed system.
(Technical Manual Illustrated Parts Breakdown USAF Models R-4360-20WA and -35B Aircraft Engines)

Centrifugal impellers simply impart immense kinetic energy to the fuel/air mixture. The trick in good supercharger design is how to convert this kinetic

The Piston Engine Revolution

energy into pressure energy, i.e., manifold pressure. This task is accomplished by the diffuser and to a lesser extent, the supercharger housing. Surrounding the impeller, the diffuser is made up from a number of vanes with an airfoil section. In this way, fuel/air flung out by the impeller is picked up by the diffuser's vanes and directed into the annulus of the blower rim. Seven circular discharges then feed fuel/air mixture into the seven intake manifolds.

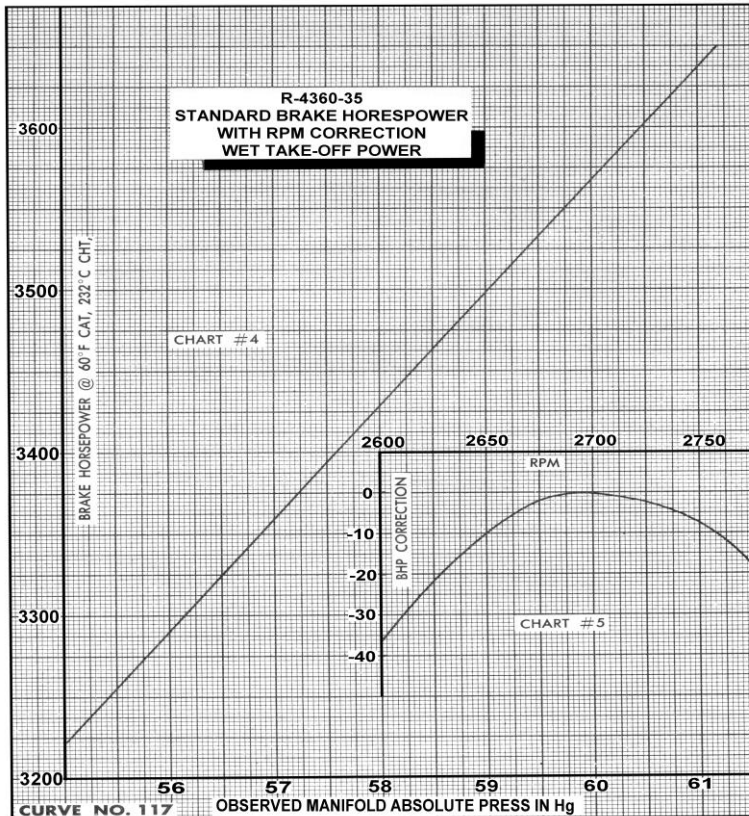

Figure 23. Power output versus manifold pressure.

Figure 23 gives an indication of the pressures achieved by supercharging in the R-4360-35 variant of the engine. It shows that power output is directly proportional to the inlet manifold pressure. As the graph shows, at 2700rpm, it reaches 3650 bhp at a manifold pressure of 61 inches of mercury. This corresponds to 2.066 bar absolute. The subsidiary graph shows the effect of small changes in rpm from design speed. Note that these performance curves are with water injection.

Accessory Drive Case

As related above, the R-4360 was designed to be as flexible as possible. This means that with relatively minor modifications, it could power everything from a single-engine fighter to multi engine strategic bombers. For example a R-4360-35 which would normally power a Boeing B-50 bomber. The 3,800hp is achieved with the aid of ADI and 61.5in.Hg manifold pressure and 2,800rpm. Power ranged from 3,000hp for early production models to 4,300hp for the VDT variants

Part of this flexibility was the use of auxiliary superchargers and pusher installations with fan-assisted cooling. Typical radial engine design locates accessories such as starters and generators at the rear and mounted in the same longitudinal axis as the engine. Not only did this increase the length of the engine, it also negated the possibility of easily mounting a cooling fan or a bolt-on auxiliary supercharger on the rear face of the engine.

In contrast Pratt & Whitney engineers thought laterally. A large ring gear, integral with the accessory drive shaft driven off the rear of the crankshaft was essentially a “one stop shop” for all accessory drive requirements. Somewhat reminiscent of the ring gear in the rear axle of a truck, numerous gears engaged this central ring gear. Disposed radially around the periphery of the rear accessory case, pads were supplied for essentials such as the starter, fuel pump, hydraulic pump(s), tachometer generator, etc.

In some cases, the speed output would not have been correct if the drive gear engaging the accessory drive gear simply drove the requisite accessory. To overcome this, intermediate jackshafts were interspersed so the correct output speed was obtained via appropriate intermediate gearing. Another key requirement of the accessory drive case was that of providing a mounting surface for the truly massive carburettor. Following prior Pratt & Whitney practice, the carburettor is mounted on a rectangular pad set at an angle. This pad opens up into the inlet throat of the supercharger. The fuel feed valve is installed behind the carburettor and intersects the annular groove for the slinger-ring which is integral with the supercharger impeller.

Power Control Unit

Almost from the dawn of aviation the Eclipse Corporation supplied many aircraft accessories such as starters and generators. With this wealth of aviation experience, they delved into the design and manufacture of automatic controls. One aspect of many US-built aircraft engines that created some problems was the lack of an automatic boost control. In other words, a pilot could, and often did, over-boost an engine. Situations such as a high gross-weight take-off and combat situations often saw manifold pressures soar to astronomical values. If the engine did not suffer severe damage, it often needed intensive maintenance after over-boosting. However, airlines in particular, did not embrace the concept of automation. Their argument seems to have been “That’s what we pay flight engineers and pilots

The Piston Engine Revolution

for!”. And unlike military aircraft, commercial aircraft are supposed to fly under well regulated conditions, in which panic-stricken, full-throttle operation, regardless of altitude, is a not a requirement. Another negative consideration was that automatic systems often proved to be a maintenance headache, adding to passenger costs. The military, because of experience during the first few years of WWII, in which American designed engines had been wrecked, got Eclipse to develop an automatic boost control for the R-4360.

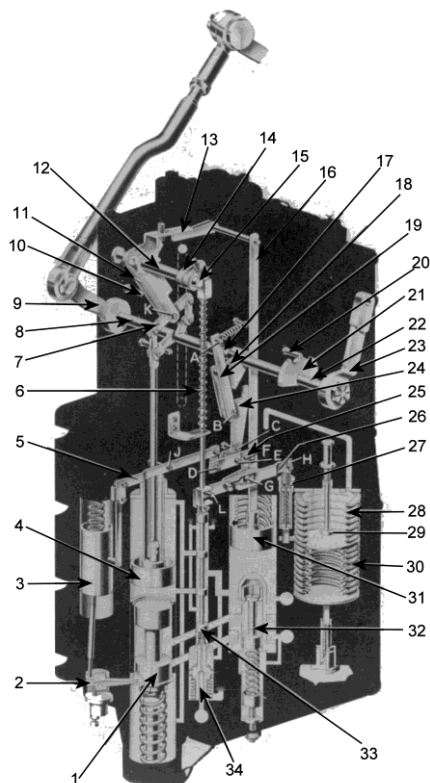

Figure 24. This is an Eclipse unit which attaches to the side of the accessory case.
1 Flow regulating valve plunger, 2 Follow-up arm, 3 Follow-up piston, 4 Operating piston, 5 Follow-up lever, 6 Push rod, 7 Walking beam, 8 Throttle shaft, 9 Throttle lever, 10 Stop pin, 11 Throttle linkage arm, 12 Manual control shaft, 13 Manual control arm, 14 Manual control shaft driving arm, 15 Push rod end, 16 Manual control piston rod, 17 Rear pilot's shaft, 18 Selector cam, 19 Cam follower arm assembly, 20 Stop pin, 21 Pilot's control shaft stop, 22 Front pilot's shaft, 23 Pilot's control lever, 24 Cam follower plate, 25 Reset walking beam, 26 Bellows walking beam, 27 Collapsible link, assembly, 28 Pressure bellows, 29 Bellows stop, 30 Evacuated bellows, 31 Manual control piston, 32 Pressure reducing valve, 33 Pilot valve, 34 Drain valve.

(Wasp Major Models B6 and CB2 Overhaul Manual Issued June 1953)

The Piston Engine Revolution

The Eclipse power control unit is attached to a pad on the left side of the accessory drive case (Figure 24). It performs the task of automatic boost control, in other words, even if the throttle was pushed all the way forward, particularly at low altitude, there would be no danger of over-boosting the engine. With this control unit, one cockpit control is required which operates and coordinates the carburettor throttle and supercharger fluid drive coupling selector valves. As an automatic power manifold pressure regulator, it maintains a constant manifold pressure regardless of change in altitude. This is accomplished via an aneroid bellows set-up which regulates the throttle in conjunction with the supercharger impeller speed. Sufficient engine oil is metered into the low ratio supercharger fluid drive couplings to maintain maximum low ratio impeller speed during operation over the part throttle power range. With an increase in supercharger demand, i.e., increased manifold pressure requirements, beyond full throttle, the pair of high ratio fluid drive couplings replace the low ratio drive fluid drive couplings in driving the supercharger impeller. Supercharging requirements in high ratio are controlled by metering the appropriate amount of pressure oil to the high ratio fluid drive couplings. This arrangement permits, in high ratio, the most appropriate control of the manifold pressure when for operating at full throttle. It ensures, in particular, that the supercharger impeller is driven at the appropriate speed without over boosting. At reduced power, the supercharger impeller is driven at the lowest speed which will maintain the desired manifold pressure.²² This latter point is key when it is understood that the drive requirements of an R-4360 supercharger can run into the hundreds of horsepower, which has to be taken from the engine. Because of its complexity, only a relative few R-4360s were fitted with the power control unit.

Auxiliary Cooling Fan

Several R-4360 applications demanded an auxiliary cooling fan. These applications included the Convair B-36, Figure 25, and Northrop's B-35. Both of these aircraft were pusher installations with the engines buried in the wing. This type of installation demanded a forced airflow over the engine to augment cooling, particularly on the ground. Pratt & Whitney used a very similar design to drive the fan as that used on the variable speed supercharger.

The fan, mounted on the rear accessory case, has two ratios, high and low with fluid couplings being employed. Due to the increased drive requirements of the high ratio, two fluid couplings were engaged to drive the fan in high ratio and one fluid coupling for low fan speed. All couplings were driven off the accessory shaft. Step-up gears engaged the couplings from the accessory drive shaft. Couplings were fed with engine oil via hollow shafts and conduits. The drive train employed the use of sun and planet gears to drive the fan, which ran co-axially with the crankshaft. In this way, cooling for the R-4360 could be optimised according to operating conditions. Of course, the extra cooling comes at a price of over 200 horsepower under some conditions. Depending on the installation, some

The Piston Engine Revolution

of that 200 horsepower could be recovered through optimising cooling airflow to augment thrust. A sophisticated fan brake was installed for when the engine was shut down.²³

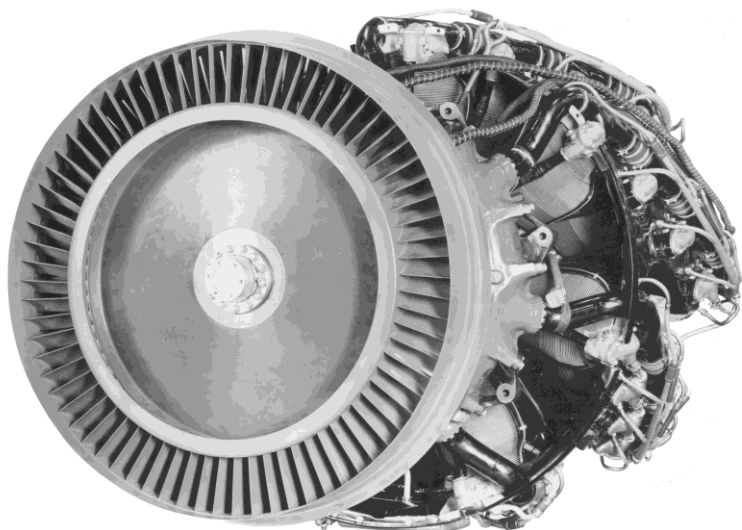

Figure 25. Several aircraft powered by the R-4360 used the so-called buried installation or the engine was so tightly cowled that fan assisted cooling was required. This shot shows an early B-36 unit and as can be seen, the cooling fan is driven off the rear case. Some installations, such as the Republic X-12 Rainbow, drove the fan from the nose case.
(Pratt & Whitney Archives)

Auxiliary Supercharger

If mission profiles demanded it, due to the flexibility designed into the R-4360, it was easy to install an auxiliary supercharger stage onto the rear accessory case, Figure 26. Again, in a similar fashion to the main supercharger stage, drive was provided through fluid couplings. Several variations were possible; a fixed ratio driven by a two-stage step up gear train, in conjunction with a variable speed drive. Alternatively, two sets of fluid couplings could be employed, each set giving a variable speed within a defined range. Yet another variation on this theme was a remotely mounted auxiliary supercharger driven off the accessory drive shaft.

An example of this configuration was the Republic XP-72. This aircraft mounted its auxiliary stage supercharger behind the pilot. In all probability this was done to maintain the aircraft's centre of gravity. The XP-72 was based upon the P-47 which has a large and heavy G.E. Type C turbosupercharger mounted in the rear. But none of the gear driven two stage engines went into production. Nevertheless, they did power a number of interesting experimental aircraft. Apart

The Piston Engine Revolution

from the Republic XP-72 mentioned above, the Boeing XB-44 and Boeing XF8B-1 are two such examples.

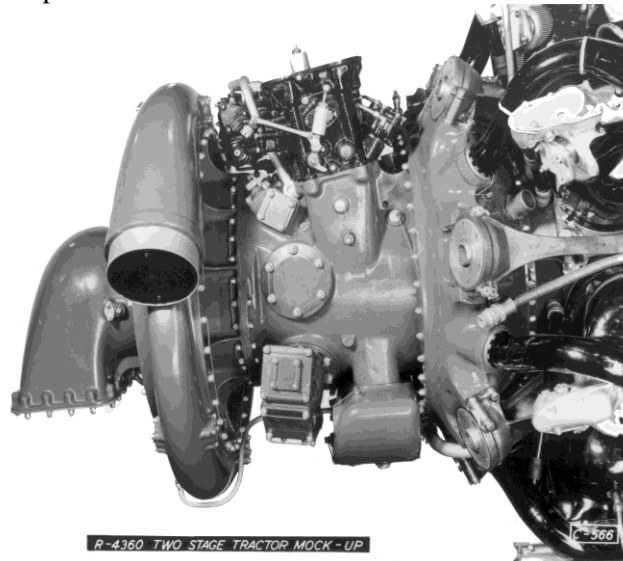

Figure 26. This close up view shows the auxiliary supercharger. It is open to debate whether or not a gear-driven two-stage supercharger would have been preferable to a turbosupercharger for altitude performance. (Pratt & Whitney Archives)

By the 1940s, in America, applications that demanded multiple stages of supercharging relied on turbosupercharging as the preferred method of boosting, particularly at high altitudes. In retrospect, it could be argued that mechanically driven two-stage supercharging may have proved to be more dependable. From the records the most problematic R-4360s were those that employed turbosupercharging. “Open stack” engines seemed to have enjoyed a far more peaceful existence. These obviously avoided the high temperature materials problems of turbocharger, but it also meant that the valves were subject to lower exhaust system pressures.

Conclusion

Notwithstanding its challenging history, the R-4360 was the right engine at the right time. Even though the early proof-of-concept engine was apparently trouble-free, it did not have to endure the hardship of passing a 100-hour type test either. Furthermore it was rated at a modest 2800hp, i.e., 100hp per cylinder, the same as the contemporary R-2800. It filled the gap between early gas turbines and the last of the big piston engines. It soldiered on for the military into the 1970s powering KC-97s and C-124s. After retirement from the military, a number of fire bomber companies used the prodigious hauling capability of the KC-97 for fighting fires. Alas, all good things come to an end and as this is written only a couple of R-4360

The Piston Engine Revolution

powered aircraft are flying. These include a Sea Fury converted to R-4360 power and a restored Goodyear F2G. The Berlin Airlift Commemorative Group is restoring a C-97 for exhibition.

References

1. G.E. Armbruster, *History of the Development of R-4360 Engines* (Pratt & Whitney Aircraft, East Hartford, Connecticut, n.d., located in Pratt & Whitney Archives).
2. Donald S. Hersey, *Memorandum Report – Dynamometer Cooling Investigation of Wasp Major Engine X-109* (Pratt & Whitney Aircraft, East Hartford, Connecticut, 20 April 1942, located in Pratt & Whitney Archives).
3. Certificate issued by Pratt & Whitney acknowledging the first flight of the Wasp Major.
4. *Wasp Major B Series Engines, Pratt & Whitney Aircraft Installation Handbook* (Pratt & Whitney Aircraft, East Hartford, Connecticut, February 1953).
5. *Wasp Major Models B6 and CB2 Overhaul Manual* (Pratt & Whitney Aircraft, East Hartford, Connecticut; reissued June 1953, revised December 1957).
6. US Patent 2,426,877 *Radial Aircraft Engine* (US Patent Office (USPTO), patented 2 September 1947); US Patent 2,666,418 *Means For Balancing Piston Engines* (USPTO, patented 19 January 1954).
7. US Patents 2,426,874-6, all entitled *Radial Aircraft Engine* (USPTO, all patented 2 September 1947).
8. Hersey.
9. *Wasp Major B Series Engines, Pratt & Whitney Aircraft Installation Handbook, ibid.*; US Patent 2,426,871 *Air Cooling For Radial Engines* (USPTO, patented 2 September 1947).
10. US Patent 2,426,871.
11. Donald S. Hersey, *Memorandum Report #403. Fin Cooling Analysis for Altitude Operation of the Wasp Major Cylinder* (Pratt & Whitney Aircraft, East Hartford, Connecticut 3 June 1942, located in Pratt & Whitney Archives).
12. C. Gordon Beckwith and R. E. Gorton, *Memorandum Report #399 Valve Motion Characteristics of the X Wasp Engine No. X-109* (Pratt & Whitney Aircraft, East Hartford, Connecticut 21-29 March 1942, located in Pratt & Whitney Archives); C. Gordon Beckwith and R. E. Gorton, *Memorandum Report #406 Valve Motion Characteristics of the X Wasp Engine No. X-110* (Pratt & Whitney Aircraft, East Hartford, Connecticut. 27-30 May 1942, located in Pratt & Whitney Archives); C. Gordon Beckwith and R. E. Gorton, *Memorandum Report #409 Valve Motion Characteristics of Wasp Major Single No. S-12* (Pratt & Whitney Aircraft, East Hartford, Connecticut 21 February - 19 March 1942 located in Pratt & Whitney Archives).
13. W.D. Carlson, Experimental Test Department Short Memorandum Report. Subject: *X-Wasp Single Cylinder Volumetric Efficiency Investigation* (Pratt & Whitney Aircraft, East Hartford, Connecticut 2 April 1942 located in Pratt & Whitney Archives); *Wasp Major B Series Engines, Pratt & Whitney Aircraft Installation Handbook. ibid* (Pratt & Whitney Aircraft, East Hartford, Connecticut February 1953); *Wasp Major Models B6 and CB2 Overhaul Manual* (Pratt & Whitney Aircraft, East Hartford, Connecticut reissued June 1953, revised December 1957).
14. M.J. Breck and A.B. Swenson, Experimental Test Department:

The Piston Engine Revolution

- Short Memorandum Report:
Subject: *Results of Power Section Scavenge Study on Wasp Major Engine X-116* (Pratt & Whitney Aircraft, East Hartford, Connecticut, 1 December 1942, located in Pratt & Whitney Archives).
15. E. Esmeir, Experimental Test Department. Short Memorandum Report. Subject: *A Comparison of Pressure Drops across a Wasp Major Scavenge Pump #55221 after Several Changes had been made in the Pump Passages* (Pratt & Whitney Aircraft, East Hartford, Connecticut 19 October 1942, located in Pratt & Whitney Archives).
 16. Service Instructions. *Bendix-Scintilla Ignition System Used on Pratt & Whitney R-4360 Wasp Major Aircraft Engines*. (Scintilla Magneto Division, Sidney, New York, USA revised October, 1948).
 17. Installation, Service and Maintenance Instructions. Bendix Low Tension – High Altitude Ignition System. Used on Pratt & Whitney Aircraft Engine Model R-4360-B6 or CB2. (Scintilla Magneto Division, Sidney, New York, USA printed December 1952).
 18. *Wasp Major Models B6 and CB2 Overhaul Manual* (note 13).
 19. Williams, G.L., Report number CG-47-6. *Planetary Reduction Gears. Useful Relations for Compound Planetary*. Pratt & Whitney Aircraft, East Hartford, Connecticut. Rev. 3/23/48. (Located in Pratt & Whitney Archives); Williams, G.L., Report number CG-47-9. *Dual Rotation Reduction Gears (4360 Compounded)*. Pratt & Whitney Aircraft, East Hartford, Connecticut. Rev. 3/5/47. (Located in Pratt & Whitney Archives); AN 02-10HD-2. Service Instructions for Model R-4360-31 Aircraft Engine 1 May 1945; AN 02A-10HC-2 Handbook Service Instructions Models R-4360-17, -45 and -47 Aircraft Engines 1 August 1948.
 20. Burt L. Newkirk, Report No. 410. Memorandum Report. *The Design of Inducers for the Wasp Major Engine* (Pratt & Whitney Aircraft, East Hartford, Connecticut. 9 July 1942 located in Pratt & Whitney Archives).
 21. US Patent 2,287,021 *Fuel Supply System* (USPTO, patented 23 June 1942).
 22. AN 02A-10HC-2. Handbook Service Instructions Models R-4360-17, -45 and -47 Aircraft Engines, 1 August 1948.
 23. Ibid.

Notes on Contributor

Graham White obtained a Higher National Certificate in the 1960s. In 1969 he left the UK for an engineering position in the Bahamas and after five years he immigrated to the USA where he was employed in various engineering functions. He spent the last twenty years of his employment working for IBM where he was granted five US patents and wrote over thirty engineering papers. He has served in various executive positions in numerous organisations.

Email: redbaron301@earthlink.net