

## **The Bristol Sleeve Valve Aero Engines**

**Patrick Hassell**

***Rolls-Royce Heritage Trust***

In 1926 Roy Fedden decided the Burt-McCollum single sleeve valve mechanism promised great advantages for his aero engines. The paper describes how he and his team at the Bristol Aeroplane Company struggled to turn that promise into reality. As well as describing how Bristol incorporated the sleeve valve into their air-cooled radial engines, it covers the early experimental work, the development of the five engine types built (Perseus, Aquila, Taurus, Hercules and Centaurus) and some of their applications, and touches on the controversy over whether Fedden was right to pursue the sleeve rather than the poppet valve route.

Keywords: Perseus, Aquila, Taurus, Hercules, Centaurus, sleeve valve, Bristol Aeroplane Company, Roy Fedden.

### **Introduction**

I was lucky enough to meet Sir Peter Masefield at a Lindbergh commemoration event in 1997. He had been, among many other things, the Managing Director of British European Airways from 1949 to 1955. We got to talking about engines and he told me that he thought the Bristol Centaurus was the best of all aero piston engines – not just one of the most powerful but “the smoothest, the quietest and the most reliable.”

Sir Peter had met the Centaurus in the graceful Airspeed Ambassador. It was by then a mature engine, and the ultimate expression of Roy Fedden’s Bristol sleeve valve designs. Getting to that stage had been a long and often troubled journey of which this paper highlights some aspects

### **Fedden’s Early History**

The Burt McCollum single sleeve valve system had been patented back in 1909. Two engineers had come up with the idea independently and rather than fight they agreed to pool their patents. They were James McCollum, a Canadian, and Peter Burt (Figure 1), of the Acme Machine Company in Glasgow. Burt took his idea to the Argyll Motor Company who showed their new 15/30 car with sleeve valve engine at Olympia in 1911. That car had another remarkable innovation – four-wheel brakes. It is likely that Roy Fedden (Figure 2) saw the Argyll at Olympia. His own career had really taken off at the same show four years earlier when a car he had designed during the last year of his apprenticeship was displayed there. He

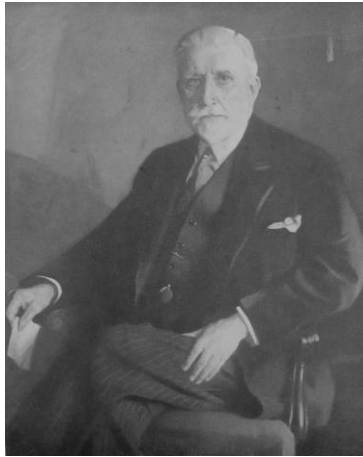

Figure 1: Peter Burt. Co-inventor of the single sleeve valve.



Figure 2: Sir Roy Fedden and Leonard Butler. The men who turned the sleeve valve into reality.

had taken the design to J.P. Brazil of Brazil Straker, a Bristol firm, who made a prototype (Figure 3). The reaction at Olympia was so enthusiastic that they put it into production as the Straker Squire and Brazil made the 22-year-old Fedden “Chief Engineer” of the Brazil Straker motor works at Fishponds, in Bristol. Around 1911 Leonard Butler (Figure 2), a talented designer-draughtsman, joined Fedden there. He was even younger than Fedden but already had experience at David Brown and Rolls-Royce. Butler rapidly became Fedden’s right hand man, and would remain so for over 30 years, turning RF’s ideas into beautiful, practical,

## *The Piston Engine Revolution*

engineering drawings. From 1916 every part in their new engines was identified by a number prefixed “FB” – Fedden & Butler, a system which continued through all the Bristol piston engines.



Figure 3: The sleeve valve Argyll 15/30 of 1911.

During the Great War Fedden made, among many other things, Rolls-Royce Falcon engines for the Bristol Fighters built at Filton, north of the city. Just before the end of the war his own design of a much more powerful engine, the 440 shp Jupiter (Figure 4), ran for the first time. This was a nine-cylinder air-cooled radial, lighter than competitors, and showed such promise that when Fedden’s parent company, Cosmos, went bust the Air Ministry persuaded the Bristol Aeroplane Company to take it on. This is how Bristol engines began and in 1920 Fedden, Butler and the nucleus of their team moved from Fishponds to the hangars in the Patchway corner of Filton aerodrome. By the end of the 1920s the Jupiter was arguably the most successful aero-engine in the world. Almost 10,000 of them were built, 80% of them abroad as it was licensed in sixteen countries from France to Japan.

The Jupiter spawned a series of engines based on the same basic cylinder technology: Lucifer, Titan, Neptune, and from 1932 the second-generation Mercury and Pegasus. The latter ultimately developed 1,065 shp, 140% more



Figure 4 The Brazil Straker or Cosmos Jupiter which became the basis of a long line of radial engines from Bristol.

than the original Jupiter from the same capacity, and it powered the early Wellington bombers. All these engines had pushrod-operated overhead poppet valves, two inlet and two exhaust. Initially these were vertical, but in the late 1920s Fedden adopted inclined valves in a penthouse head that Farnborough had shown to be superior. Even as this change was being introduced Fedden was exploring another way to improve his engines' breathing and power output. He may have been attracted to this as the early engines had problems with valves, according to Sam Heron, as in his wicked way, claimed that the Jupiter should have been judged on the pounds of valves per hour it used rather than on the fuel consumption.

### **The Sleeve Valve Background**

Fedden had never forgotten the single sleeve valve. Beside Argyll's 15/30 car, he had seen their six-cylinder sleeve valve aero engine. This had won the 1913 military trial but had not saved the firm from going out of business in 1914. Postwar, a few others had experimented with Burt's system, including Continental in the USA but no production followed. Barr & Stroud however sold a 350 cc motorcycle engine using a Burt sleeve (Figure 5). Fedden bought one of these in 1922 and tradition says the one handed down to the Rolls-Royce Heritage Trust (RRHT) is that very engine.



Figure 5 The Barr and Stroud sleeve valve motor cycle engine.

Harry Ricardo was also working on single sleeve designs for Vauxhall, for although Ricardo had identified aromatic fuels as having inherently high octane ratings, he did not think that there was much chance of a big improvement. As it was, at just about the time that Ricardo and Fedden got together, Midgely in the USA was being given a prize by the American Chemical Society for the discovery of tetraethyl lead. In future years, however, when massive doses of TEL were to be employed, corrosion of poppet valves became a dominant issue in engine design. Sleeve valves were immune, of course.

Nevertheless Ricardo and Fedden had collaborated since the Fishponds days and in May 1924 Fedden asked him about the possibility an air-cooled sleeve valve unit. The UK Government's Aeronautical Research Committee (ARC) thought that air-cooling would prove very problematic but still considered the sleeve valve a very promising route to engines of higher power to weight ratio. This was before the advent of sodium-cooling and hot exhaust valves were a regular source of pre-ignition. Ricardo had found that on a given fuel the sleeve valve allowed him to increase compression ratio by a whole unit before detonation occurred e.g. from 5:1 to 6:1. This was a great attraction in itself but it was also expected that sleeves would cope better with the experimental leaded fuels which seemed so promising.

So in late 1926 Bristol embarked on its own air-cooled design, having gained support from G P Bulman at the Air Ministry. By May 1927 Fedden told Ricardo the engine was nearly ready and asked his advice on running clearances, though it seems it did not actually run until August.

Fedden was then considering a V-12 design for the production sleeve valve engine and this first test unit was a 60° V-twin (Figure 6), using the 5.75-inch bore

## *The Piston Engine Revolution*

common to almost all Bristol engines. The sleeves were made of a nickel iron as used by Ricardo. The trouble these gave, including parts of the sleeve “blowing out”, would not be the last. But after considerable modification and further tests on single-cylinder units, in 1931 a 100-hour test at 2,000 rpm and a bmep of 120 psi was achieved. By then the test engine had increased cooling fin area and the sleeves were Keyser Ellison KE965 steel. This was regarded as a turning point and from then on Fedden saw the sleeve valve as the way forward.

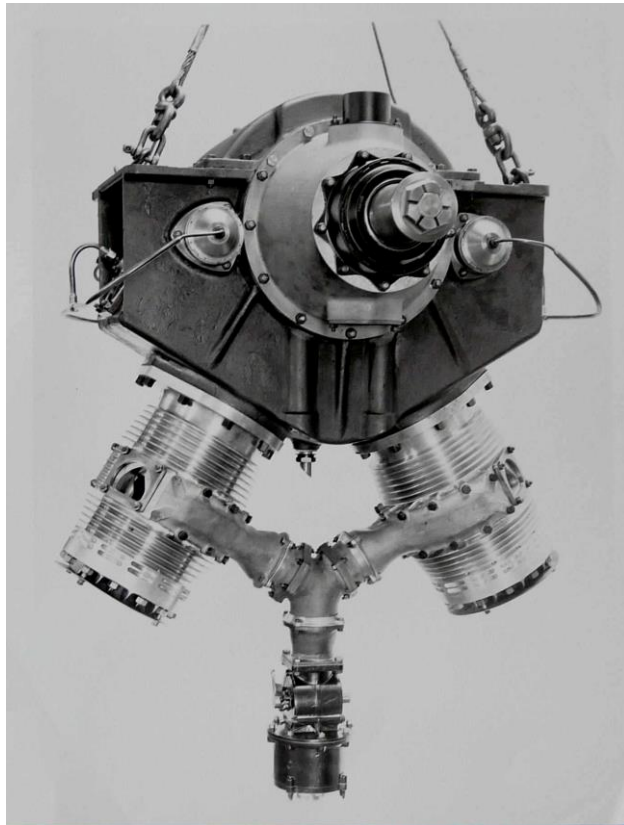

Figure 6 Fedden's twin cylinder Vee, used to investigate the sleeve valve configuration.

At around the same time the decision was taken to revert to the nine-cylinder radial for the sleeve valve engine and the name Perseus (Figure 7 and 8), which had already been used to refer to the V-12 design, was carried over to the new radial. Its bore and stroke were identical to the poppet valve Mercury at 5.75 by 6.5 inches giving a capacity of 1519 cu.in or 24.9 litres. The prototype ran in 1932 and that first engine, identified as PR.100, is still in the RRHT collection 79 years later.



Figure 7 The Bristol Perseus. The first successful sleeve valve radial.



Figure 8 The prototype Perseus being overhauled in 2011.

The design of the Perseus set the pattern for all the subsequent Bristol sleeve valve engines, which despite extensive development, stuck to the same basic design. The sleeves are driven by simple offset crankpins mating with spherical bearings bolted to the bottom of the sleeve (Figure 9). The sleeves thus follow a

sinusoidal path between bottom and top dead centre over a stroke of about 2.5 inches. The cranks are driven at half engine speed by a train of gears mounted on the front of the crankcase wall.

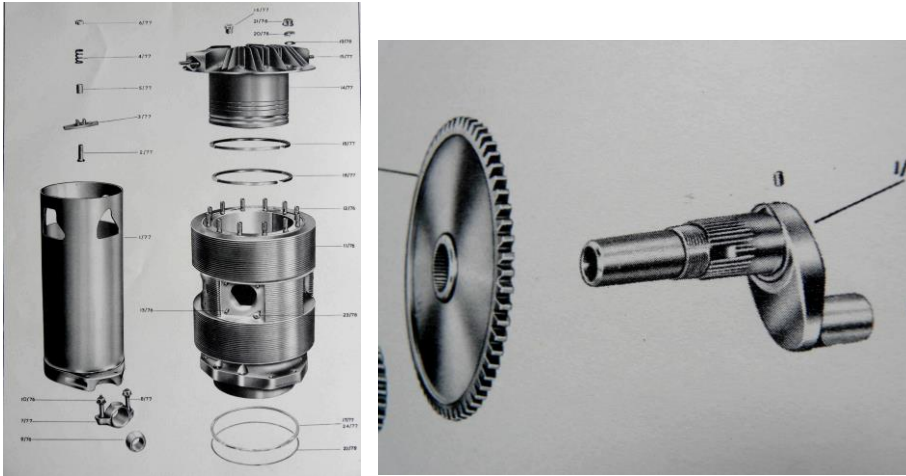

Figure 9 Sleeve and engine cylinder and sleeve valve crank.

As the sleeves rise, turn and fall, ports in the sleeve uncover the corresponding ports in the cylinder, two exhaust ports at the front and three inlet ports at the rear, covered by a common manifold belt. The sleeve itself has only four ports as one of them manages to act as both an inlet and exhaust in turn. Because the top of the sleeve rises well above the combustion chamber the cylinder is capped by a deep “junkhead” which provides the annular slot for the sleeve, sealed by compression rings. The twin 14mm spark plugs are fitted centrally but are deep down in the well of the junkhead. It was always feared that cooling these would be a major problem, but with careful baffling to ensure sufficient airflow satisfactory cooling was obtained.

The remainder of the engine largely followed current Bristol practice on the poppet valve Mercury and Pegasus (Figure 10) that in 1932 were just about to supersede the Jupiter in production. There was a master con rod with integral big ends for the eight slave rods. Because this was a single-piece unit the crankshaft was in two parts, the rear web being fitted to the crankpin by a bolted Maneton clamp, just like that used to secure the height of bicycle saddle.

In front of the sleeve-drive chest was the Farman-type propeller reduction gear. This could be built provide a small range of ratios, though 0.5:1 was most common and used on the Perseus. Accessories were driven from the rear of the crank, as was the centrifugal supercharger, via its own train of sprung gears with integral clutches.



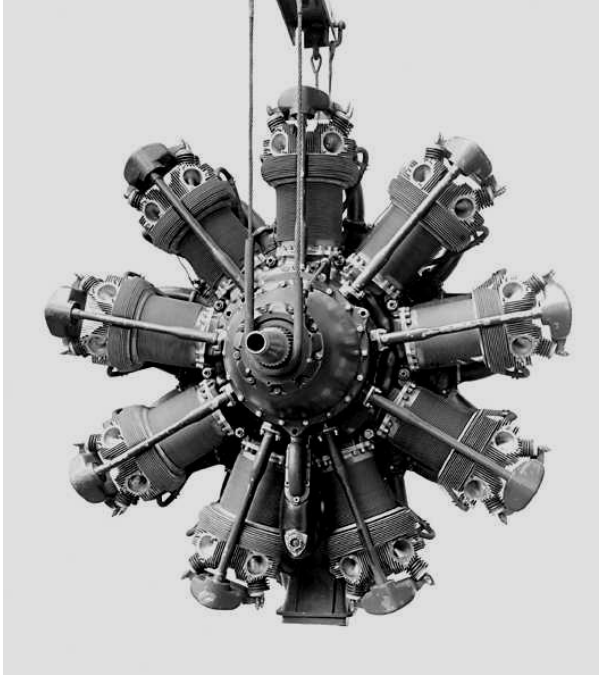

Figure 10 The Bristol Pegasus. Note the pushrods used to open the inlet valves.

This layout gave a compact and exceptionally clean, uncluttered engine. And when running it was as smooth as it looked, which much impressed everyone who saw it. The thousands of hours of single-cylinder work paid off, with the Perseus passing its first Type Test in May 1933.

The directors, encouraged by the Perseus' progress, had authorised the building of its little brother, the Aquila (Figure 11), aiming for 500 shp. Still with nine cylinders, but of just 5-inch bore this 15.6 litre engine ran in October 1933, the same month that the Perseus took to the air in the company's own Bulldog test bed, the first sleeve valve engine to fly.

Bristol naturally trumpeted all this success and apart from the smoothness stressed the many other advantages of the Burt McCollum sleeves: a huge reduction in parts count, and end to problems of valve bounce and spring breakage, and the virtual elimination of maintenance.

Imperial Airways were so impressed by all this they asked if their new Short's "Empire" flying boats could be fitted with the Perseus, but at that stage it did not meet the power requirement. Imperial accepted the larger Pegasus poppet valve engine instead. However, they did replace two of the four Jupiters on their Short L.17 airliner, *Syrinx*, with the Perseus, which entered service in

## *The Piston Engine Revolution*

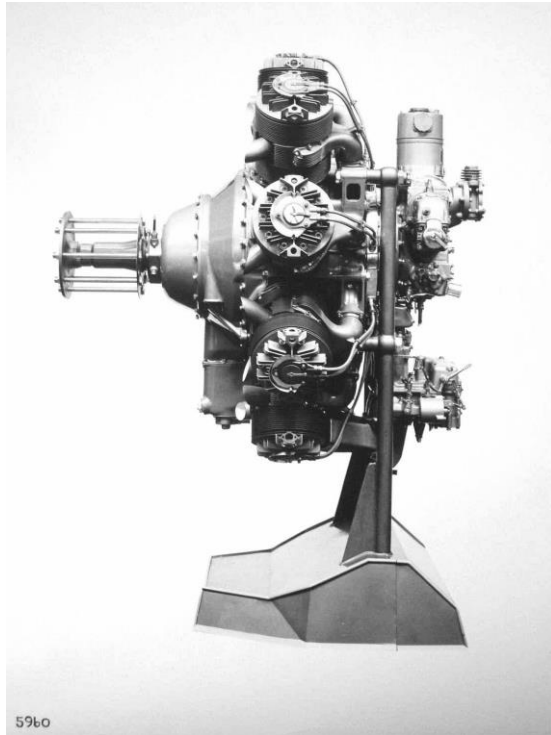

Figure 11. Bristol Aquila.

June 1935. The engines were cleared for an initial TBO of 300 hours, remarkable at that time. They required minimal maintenance and when stripped were in excellent condition. The RAF also tested the engine in a Vildebeest, which flew 200 hours with no attention other than to the ignition and filters.

### **The Challenge of Mass Production**

So the future of the sleeve valve looked assured. There was just one fly in the ointment. All these early engines had individually matched cylinders, sleeves and pistons and were hand finished. Finding a combination of materials, processes and techniques to mass produce reliable, interchangeable sleeves with the required strength and wear characteristics proved a nightmare. Fedden would attend the directors' meetings and explain that the last solution, which had seemed so promising, had failed on test but there was this new material or process which he "...was confident would get us out of the wood". This pattern was repeated time after time.

Fedden later estimated that it had cost the Air Ministry and Bristol some £2 million to find the answer. This at a time when the Ministry was buying new

## *The Piston Engine Revolution*

Pegasus and Mercury engines for less than £2,000. Many since have since questioned if it was worth it. One postwar American engineer called the sleeve valve “an excellent solution to a non-existent problem”. The massive amount of development of both the Pratt and Whitney and the Wright engines, and the design compromises needed might counter this opinion. In particular, for multi-row radials, it was mechanically complex to use four poppet valves per cylinder, so American engines had to use one large inlet and one large exhaust valve. The inlets were no real problem, but as Dr Starr has mentioned in his paper, the American had to develop hollow head, sodium cooled valves to get the heat out of the exhaust valve crowns. Unfortunately this tended to push the heat into the valve stem, and with engines in the Superfortress there was a real chance of valve stem failure on the hot, overloaded take offs from Iwo Jima.

Fortunately Fedden was not a man for doubts – his comparative performance tests had shown the sleeve was superior to both Bristol four-valve and American two-valve cylinders – and he firmly believed there was a solution to every problem *if you just worked hard enough*.

And work they did. At Firth Vickers, A.E. Thornton worked through fifty eight specially tailored alloys and over 1,100 different heat treatments before they settled on a high-expansion, centrifugally cast, Ni-Cr-Mo steel, nitrided all over. Centrifugal casting was an innovation in its own right, in which molten metal is poured into a rotating cylindrical mold, and the centrifugal action forces the metal against the mold wall, where it solidifies. The imperfections in the casting are forced to the inside wall where they are machined off. Nitriding gives a very hardwearing surface, which does not “pick up” under conditions of poor lubrication. Matched with a cylinder forged from a low-expansion aluminium alloy developed by HDA and containing 12% silicon this minimised the variation of running clearances. But it was still impossible to keep the sleeves adequately circular as the sleeves passed through the various heat treatment procedures. The final answer was stumbled on by accident when an operator finished a batch of sleeves with a worn out grinding wheel incapable of cutting. They were found to be almost perfectly round.

This accident was refined into a production method and patented. Both the US and Swedish patent offices refused to grant the patent on the grounds that it could not possibly work. They only relented after Harry Ricardo himself sent them a letter confirming he had been to Bristol and personally witnessed the process and measured the sleeves before and after. They had been brought from 5 “thou” ovality to less than a “thou” while removing under half a “thou” from the outside surface.

That was in March 1938 and the engines could finally go into mass production with confidence. Not before time, as several important aircraft were already committed to using them. The Perseus, at around 800 shp was now too small for the latest military types. It had been adopted for the Blackburn Skua and

## *The Piston Engine Revolution*

Roc and their twin-engined Botha but all of these proved inferior designs and were soon relegated to second line duties. Perseus also powered the Mk.2 Lysander and in the civil arena it made history in the Shorts S.30 flying boats by inaugurating the first scheduled transatlantic services in the summer of 1939.

The little Aquila was eventually dropped as the great expansion of production for the RAF began from 1935, but its five-inch cylinders were used to create a new two-row, fourteen-cylinder engine called the Taurus (Figure 12). The Bristol Aircraft Company directors approved development of this 1050 shp engine in October 1935. It was soon called on to replace the Perseus in Bristol's new Beaufort torpedo bomber (Figure 13), when changes in specification resulted in the aircraft weight outgrowing the power of the Perseus. The RAF's need for this aircraft to replace the biplane Vildebeest put great pressure on Taurus development and resulted in the engine going into service before all the problems had been fully sorted.

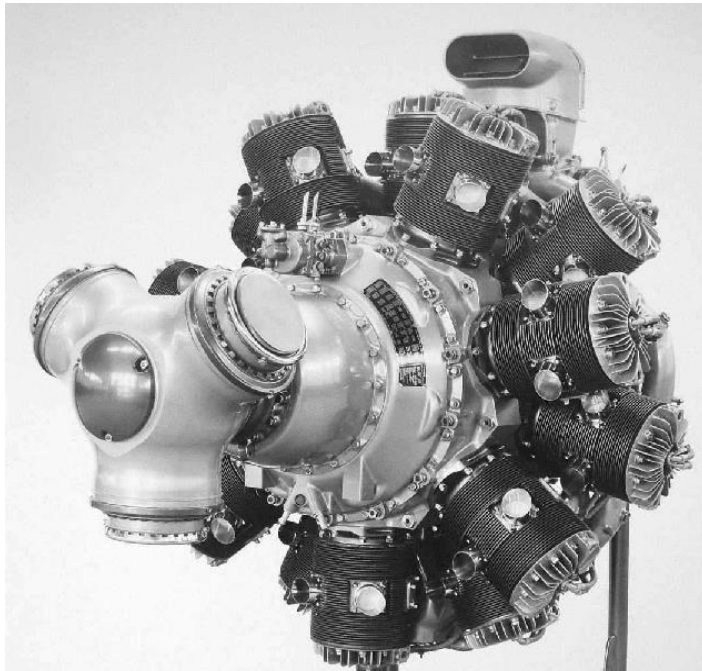

Figure 12. The Bristol Taurus. The first two-row sleeve valve radial.

A particular problem was the crankshaft maneton clamp that was a so-called "hairpin" design which Ricardo had used successfully. Bristol however found it unreliable and of course if the maneton slips engine failure is inevitable. The problem was compounded by the Beaufort not having feathering propellers and thus being unable to fly on one engine except at very low weight.



Figure 13. The Bristol Beaufort torpedo bomber. Engine failures of the Taurus in this aircraft lead to the maneton clamp having to be redesigned.

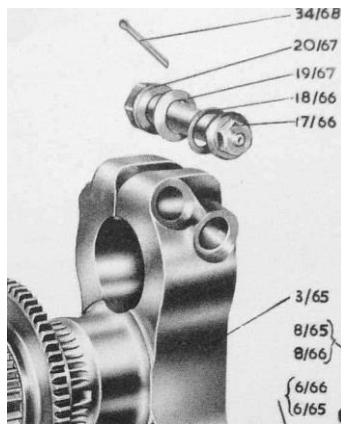

Figure 14. Improved design of maneton clamp incorporating two bolts.

A successful two-bolt clamp (Figure 14) replaced the hairpin but the engine had acquired an unenviable reputation that lingered long after its problems were cured.

### **Wartime and After**

However, in May 1934, 18 months before the start of the Taurus programme, Fedden and Butler had begun design work on another two-row engine which would more than restore the reputation of the Bristol sleeve valves. It used fourteen of the larger Perseus-type cylinders giving a capacity of 38 litres and was planned to give well over 1,000 shp for bombers and large flying boats. They called it the

## *The Piston Engine Revolution*

Hercules (Figure 15), a name they'd used twice before for large engine projects that had come to nothing. But this third one would prove to be Bristol's most successful and long-lived engine and fully justify Fedden's faith in the single sleeve valve.

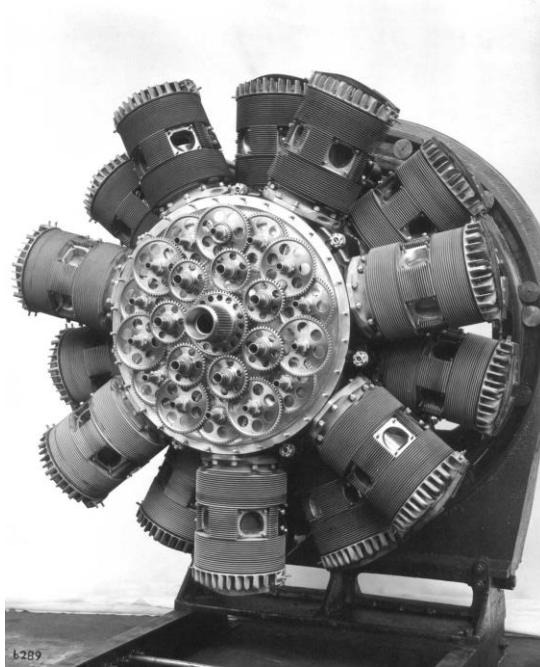

Figure 15. The prototype Bristol Hercules 1936.

Drawings were complete by March 1935 and by then Fedden was expecting 1320 shp. The prototype ran in January 1936. Development went well and the engine passed its 100-hour Type Test in February 1937. The Hercules used the two-bolt maneton from the start and this avoided the problems the Taurus experienced with the hairpin type. One problem which was encountered though was torsional crankshaft vibration (Figure 16), something then very difficult to analyse. It was cured by incorporating a Saloman damper (Figure 17). This uses a large ball on a short track inside the crankshaft web to provide dynamic damping. The first aircraft to enter service with the Hercules was the Saunders-Roe Lerwick flying boat in July 1939 but the RAF soon withdrew this undistinguished machine. Better was to come. The Hercules was adopted for the Short Stirling, then for all the later Wellingtons, the Mk.II Lancaster and all the Halifaxes from the Mk III onwards; and of course for Bristol's own Beaufighter, the original multi-role combat aircraft.

## *The Piston Engine Revolution*

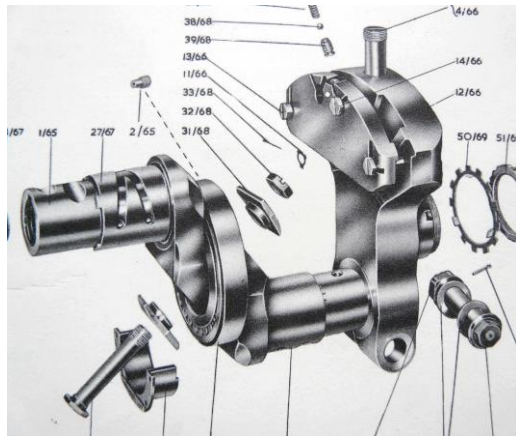

Figure 16. Hercules crankshaft and rear web.

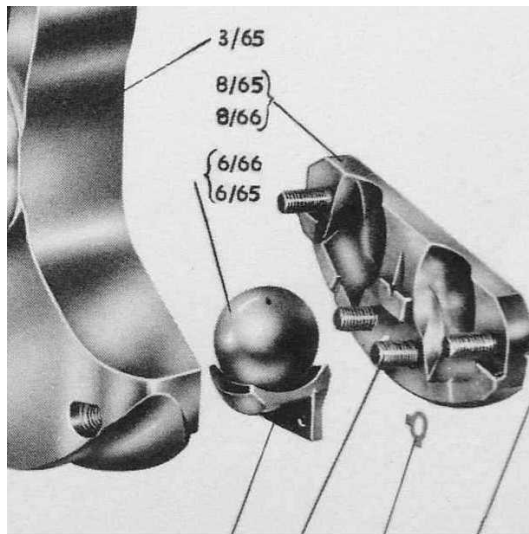

Figure 17. Saloman damper as used on the Hercules.

This required mass production on a huge scale of course. The great majority of Hercules' were built at the government-owned shadow factories, some run by a consortium of motor car firms. There was a big one at Accrington, managed by Bristol, as was the one right next to the Patchway works but fenced off and run as a separate business. Over 66,000 Hercules were built, the vast majority during the war years. Nearly 20,000 were built in 1944 alone, with monthly production peaking that March at 2,015; that is about 1,000 cylinders and sleeves every day, (Figure 18).

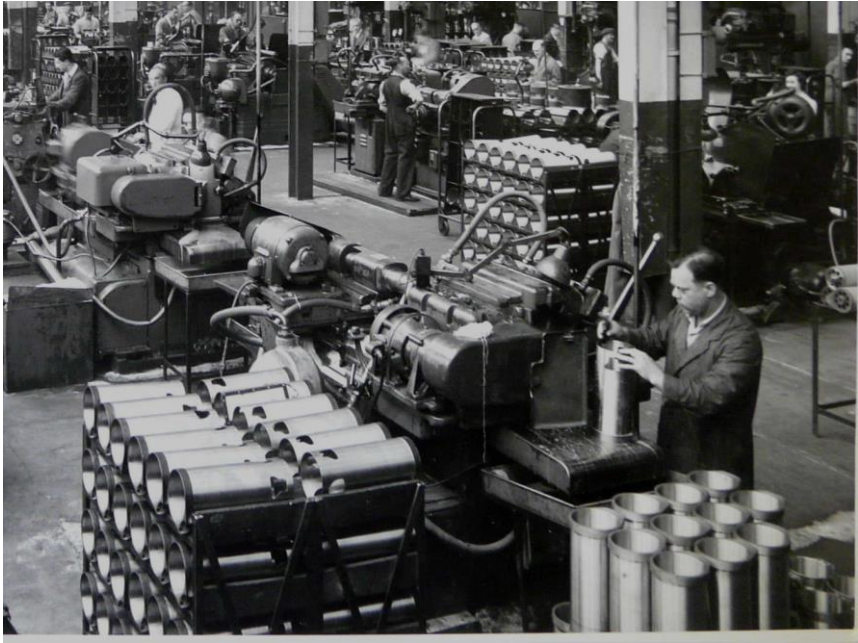

Figure 18. Manufacture of sleeve valve cylinders.

Postwar, the Hercules became the backbone of Britain's air transport fleet, both civil and military, in aircraft like the Handley Page Halton, Hastings and Hermes, Vickers Viking and Varsity and of course the Bristol Freighter, famous for the Silver City cross-Channel car ferry service.

It was in Freighters hopping across another channel, the Cook Strait between New Zealand's North and South Islands, that the Hercules' time between overhauls was finally extended to over 3,500 hours, about twice as long as their American poppet-valve rivals.

Over fifty Marks of Hercules were built, with the maximum power of production versions increasing from 1375 shp to 2140 shp. The main sources of increased power were first improved fuel and later improved supercharging. The big change in the latter was the replacement of Bristol's traditional snail-entry duct by the so-called "turbine entry" in the Mk.100 and later versions. Fedden has been criticised for not introducing the change earlier as it raised the bombers' ceiling by several thousand feet. In his defence it has to be said the Air Ministry did not give this change any priority until after Fedden had left Bristol in September 1942, an event that stunned people at the time and is still controversial.

The Hercules revived the Jupiter's tradition of license production with SNECMA, the nationalised successor to Gnome Rhone, building large numbers for the Noratlas transport and establishing a collaboration which continued with the



## *The Piston Engine Revolution*

Concorde's Olympus powerplant. In fact, Hercules production overlapped with Concorde and the Harrier Pegasus, and might have extended further, but it is said that after the merger of Bristol and Rolls-Royce in 1966 new enquiries for Hercules were politely rebuffed.

The Hercules was not Fedden's last Bristol engine. That was the Centaurus, launched in May 1937 as a response to the Rolls-Royce Vulture and aimed at 2000 shp. For rapid development it used two rows of nine Hercules-type cylinders but with an increased stroke giving a total capacity of 53.6 litres. The design was generally similar to the Hercules (Figure 19), but where with fourteen cylinders it had been possible to drive all the sleeves from a single front gear train, with eighteen it was not and the rear sleeves had to be driven by a train behind the crankcase.

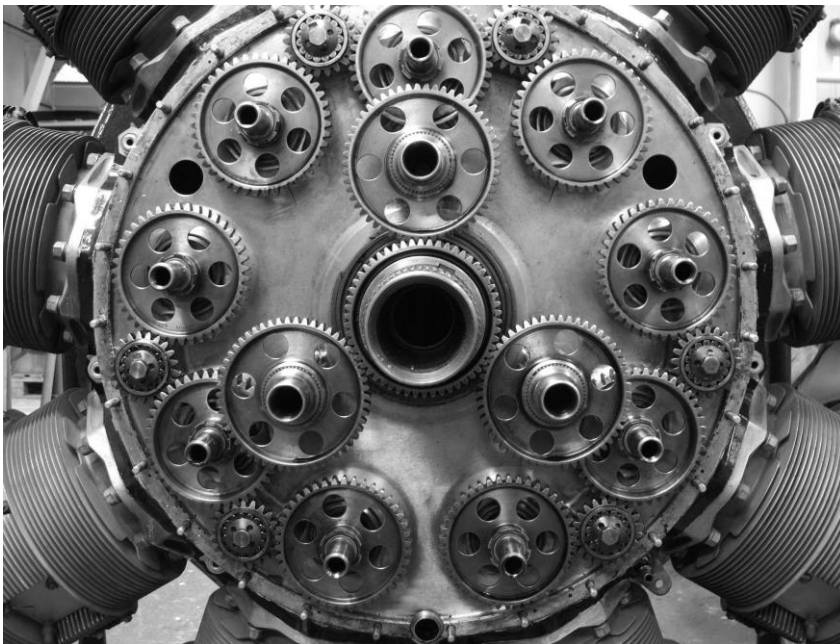

Figure 19. Drives for actuating the combined and reciprocating action of the sleeve valves.

Despite the huge pressures on the small Bristol team to get the Hercules ready for service the Centaurus (Figure 20 and 21) was given considerable priority and passed its Type Test in April 1940. But delays resulting from vacillation in Ministry policy and the decision that production should move to a new underground factory in Corsham meant that the Centaurus' contribution to the war effort was minimal. In 1945 squadrons of long range Hawker Tempest II

*The Piston Engine Revolution*

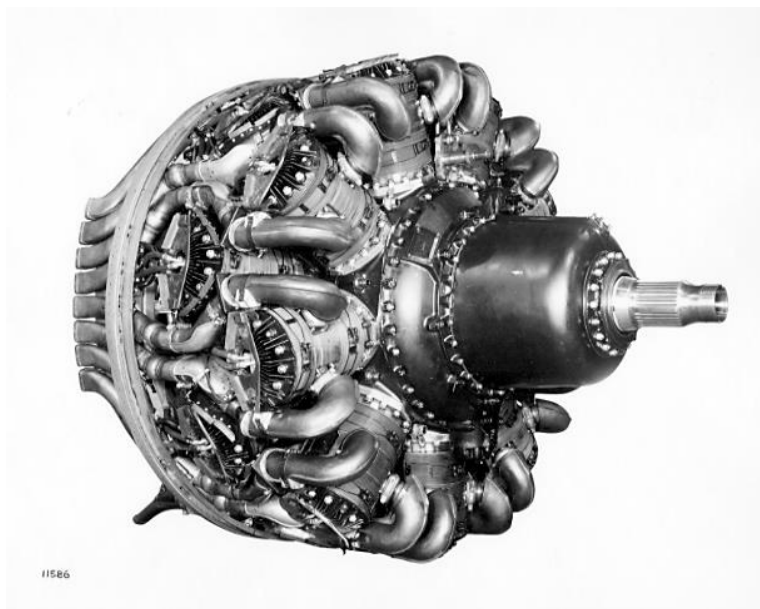

Figure 20. The Centaurus, the culmination of aeroengine sleeve valve evolution at Bristol .



Figure 21. A Centaurus at Bristol in 1966 undergoing one of its infrequent overhauls.

fighters were working up for the Pacific war, but VJ-day arrived before they did.

## *The Piston Engine Revolution*

Bristol sleeves had in fact played a role in the wartime success of the Hawker fighters but not in Bristol engines. The H-24 cylinder Napier Sabre powered the Typhoon and Tempest. Frank Halford had used single sleeve valves in this engine, driven by skew gears rather than cranks. The hand-built prototypes had behaved beautifully but production engines had woefully short lives and high failure rates. Rod Banks at the Ministry realised that the Sabre and the Taurus both had a five-inch bore and asked if Bristol could machine a set of sleeves to fit the Sabre. They did, and the Bristol sleeves worked perfectly on test. Production was immediately converted to Bristol specifications and processes and the necessary machine tools were shipped from America within a month. The Sabre became a success but died almost immediately the war was over. Rolls-Royce's last piston engine, the Eagle was also an H-24 sleeve valve, much influenced by the Sabre, but although it powered the prototype Westland Wyvern it never entered production and was superseded by gas turbines.

The Centaurus though continued in production and development, eventually surpassing 3,000 shp, though its highest rated power in service was 2,740 shp from the Mk.173. It powered the RN's last and fastest piston-engined fighter, the Sea Fury (Figure 22), and the RAF's Brigand. Eight of them, coupled in pairs and buried in the wing, powered the magnificent but misconceived Bristol Brabazon. Its main transport use was in the Ambassador airliner and the Beverly freighter which the RAF flew until 1966. It was outlasted by the Hercules, which flew on, with the RAF for another ten years. The last Bristol Freighter finally retired in 2004.



Figure 22. The Hawker Sea Fury, in which a five bladed prop is needed to absorb 2730 shp.

Today, just a few Bristol sleeve valve engines remain airworthy in Sea Furies and in a single Noratlas. But there are also several in private hands being restored to ground-running condition so there is a chance we'll be able to hear the unique sound of Fedden and Butler's wonderful engines for many years to come

## **Appendix: Notes on Materials**

At the time that Fedden began to do serious work on slide valves, the best poppet valve material was Silchrome, a relatively cheap form of stainless steel, in which the alloying elements, chromium and silicon gave good resistance to exhaust gases. However, also about this time, the mid-to-late twenties, fuels containing tetraethyl lead began to be introduced, which allowed engines to run at higher compression ratios and give much greater power. Unfortunately, valves made of Silchrome were badly attacked by the lead-rich deposits that form on valves, when fuels containing tetraethyl lead are used. Slide valves are of course immune from this type of attack. The knowledge of problems being experienced in conventional engines may well have acted to encourage Fedden.

However, the Kayser Ellingham Company in England had developed a higher quality stainless steel, KE 965, much stronger than Silchrome, containing nickel as well as iron and chromium. This proved to have rather better resistance to leaded fuels than Silchrome, although it was not a complete solution. Somewhat fortuitously KE 965, when nitrided, proved to be an ideal material for slide valves, and its availability must have accelerated development of this new range of Bristol engines.

Even today, when we have a good understanding of the processes which control friction and wear under poorly lubricated conditions, cut and try methods are often needed to ensure good reliability from mechanical components. One's perception of Fedden's insights and skill grows still further, as it was only through his hard work and perseverance that the slide valve was brought to perfection.

## **Bibliography**

Bill Gunston, *Fedden - the life of Sir Roy Fedden* (Rolls-Royce Heritage Trust (RRHT) Historical Series No.26, 1998 ISBN 1 872922 13 9).

W.J.A. Sawyer, *The Bristol Aircooled Radial Engine* (unpublished typescript in RRHT Bristol archive, 1969).

A.H.R. Fedden, 'The Single Sleeve as a Valve Mechanism for the Aircraft Engine', *SAE Transactions* 33 (Sept 1938).

Sir Roy Fedden 'The First 25 Years of the Bristol Engine Department' 7th Barnwell Memorial Lecture (RAeS Journal, May 1961), p. 332.

F.R. Banks, 'The Aviation Engine' James Clayton Lecture, *Proc of I.Mech.E.*, (1951), p. 433

John Reynolds, *Engines and Enterprise - the life and work of Sir Harry Ricardo* (Sutton Publishing, 1999, ISBN 0 7509 1712 1).

F R Banks, *I Kept No Diary – an autobiography* (Airlife 1978 &1983, ISBN 0 904543 9 7).

G.P. Bulman *An Account of Partnership - Industry Government and the Aero Engine* (RRHT Historical Series No.3, 2002 ISBN 1 872922 21 X).

Frank Nixon, 'Aircraft Engine Developments', *RAeS Centenary Journal* (January, 1966), p. 150.

John Cambell Watson, *A Brief History of the Argyll Motor Car*, (from: <http://www.scotiaweb.co.uk/argyll/page4/page4.html>)

Correspondence with Bristol Aeroplane Company in the Ricardo Company archives, Shoreham-by-Sea, BN43 5FG Bristol Aeroplane Company. Minutes of The Directors meeting in committee 1920-1943, 13 Volumes, and Maintenance Manuals and

## *The Piston Engine Revolution*

Parts Catalogues for Hercules and Centaurus engines, both in RRHT archives, Bristol.

### **Notes on Contributor**

From 1968 Patrick Hassell worked in aerodynamics and performance for Handley Page, BAC Filton, Douglas and Saab before becoming a propeller engineer with Dowty. Since retiring he has volunteered with the Rolls-Royce Heritage Trust at Bristol and researched their archives to learn more of the history of Bristol Aeroplane Co Ltd and its products.

Email: [pat\\_hassell@blueyonder.co.uk](mailto:pat_hassell@blueyonder.co.uk)